

# **INSTALLATION GUIDE**

**B5802EXPD25 & B5805EXPD25  
CARGO BARRIER  
2025+  
FORD EXPEDITION**

**Pro-gard**<sup>TM</sup>  
PRODUCTS LLC.

**STRONG. RELIABLE. SECURE.**

**THESE COMPONENTS ARE REQUIRED  
TO INSTALL THE CARGO BARRIER**

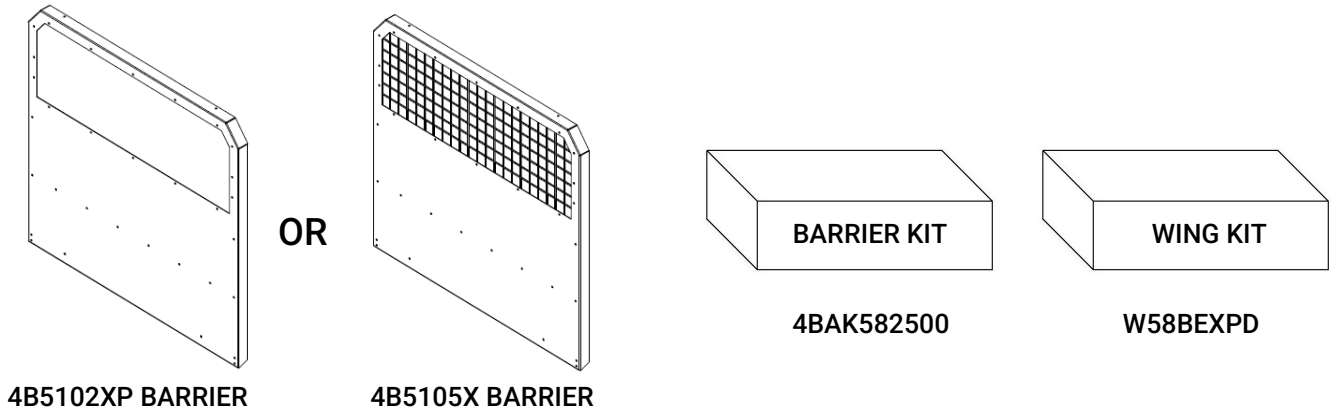

**I. The following tools will be required to complete the installation**

- A. Ratchet with 7/16" Socket
- B. Ratchet with 5/16" Socket
- C. #2 Phillips Screwdriver

**II. Read all instructions and refer to last page to ensure all parts were received**

---

**WARNING:** *Locate All wiring, fuel lines, brake lines, coolant lines, or refrigerant lines before drilling any holes or installing any self-drilling fasteners.*

---

**III. Barrier Installation**

- A. Install the upper mounting brackets (3BAR582500 driver side, and 3BAR582501 passenger side) finger tight to the top of the barrier using a (3X36) carriage bolt and (3X16Z) whiz nut on each side. The shallower bend on the brackets should face away from the barrier and bend away from the roof of the vehicle (see Fig. 1).
- B. Remove the OEM coat hook assemblies from the headliner area near the rear hatch.
- C. Place the barrier in place behind the rear seats. With the second row seats folded down, raise the barrier up and align the rear of the upper support brackets with the holes from the OEM coat hooks. Insert the (4G5070P1) spacer between the bracket and coat hook hole, pass the (3X682) #10 x 1" screw through the bracket and spacer, and loosely thread it into the coat hook hole (do this for both sides).
- D. Loosen the rear seat bolts at the base of the 2nd row seats and insert the forked end of the (3B5818-01) lower barrier brackets. Align the holes in the rear of the brackets with each side of the barrier, and fasten with two (3X36) carriage bolts and two (3X-16Z) whiz nuts at each end (See Fig 2). Retighten rear seat bolts.

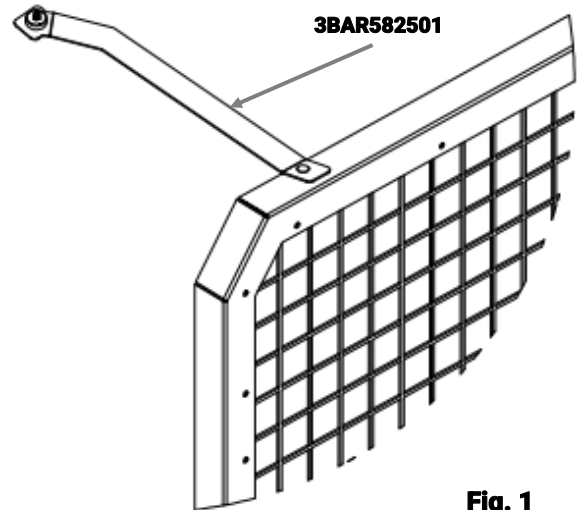

**Fig. 1**

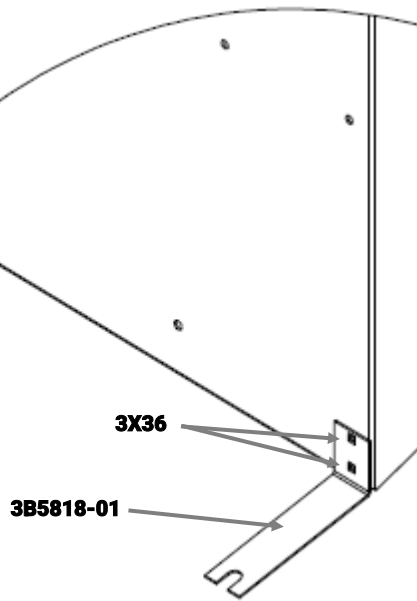

**Fig. 2**  
**(Driver's Side Shown)**

#### **IV. Install Wings**

- A. Attach the polycarbonate top panel (3BW5818-05) to the barrier using the existing bolts from the top of the barrier window frame. Hand tighten fasteners.
- B. Attach polycarbonate lower wings (3BW5818-03 and 3BW5818-04) to each side using two (3X36) carriage bolts and two (3X16Z) whiz nuts on each. Hand tighten fasteners.
- C. Attach polycarbonate upper wings (3BW5818-01 and 3BW5818-02) to each side using existing barrier window hardware. Hand tighten fasteners.
- D. Position the barrier in the center of the vehicle. Adjust the polycarbonate wings for desired fit against the interior trim and headliner. Tighten all fasteners.
- E. Installation is now complete.

B5802EXPD25 / B5805EXPD25			
ITEM	QTY	PART NUMBER	DESCRIPTION
1	1	W58BEXPD	BARRIER WING KIT EXPD 18
2	1	4B5105X / 4B5102XP	CARGO BARRIER WIRE VENT / POLY WINDOW
3	1	4BAK582500	BARRIER KIT 25 EXPD

W58BEXPD BARRIER WING KIT			
ITEM	QTY	PART NUMBER	DESCRIPTION
4	1	4BW5818-01	BARRIER WING EXPD 18 AB LEFT UPPER
5	1	4BW5818-02	BARRIER WING EXPD 18 AB RIGHT UPPER
6	1	4BW5818-03	BARRIER WING EXPD 18 AB RIGHT LOWER
7	1	4BW5818-04	BARRIER WING EXPD 18 AB LEFT LOWER
8	1	4BW5818-05	BARRIER WING EXPD 18 AB TOP WING
9	4	3X36	1/4-20 X 5/8 CARRIAGE BOLT
10	4	3X16Z	1/4-20 LARGE HEX WHIZ NUT-ZINC

4BAK582500 BARRIER KIT			
ITEM	QTY	PART NUMBER	DESCRIPTION
11	1	3BAR582500	BRACKET, UPPER BARRIER 25 EXPD DS
12	1	3BAR582501	BRACKET, UPPER BARRIER 25 EXPD PS
13	1	4BAK582501	BARRIER HARDWARE KIT EXPD 25
14	2	3B5818-01-A	LOWER BARRIER BRACKET

4BAK582501 BARRIER HARDWARE KIT			
ITEM	QTY	PART NUMBER	DESCRIPTION
15	2	4G5070P1	0.375 BLK SPACER
16	6	3X36	1/4-20 X 5/8 CARRIAGE BOLT
17	6	3X16Z	1/4-20 LARGE HEX WHIZ NUT-ZINC
18	2	3X215	#10 WASHER FLAT SAE ZINC
19	2	3X682	#10 x 1" FLANGE HEAD SHEET SCREW

