

INSTALLATION GUIDE

**2018-CURRENT FORD EXPEDITION
P1000 Pro-Cell
P1000EXPD18A**

Pro-gard[™]
PRODUCTS LLC.

STRONG. RELIABLE. SECURE.

**THESE COMPONENTS ARE REQUIRED
TO INSTALL THE P1000 PARTITION**

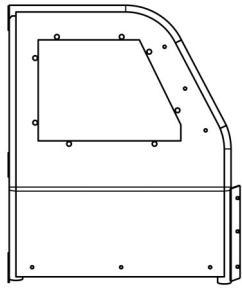

4P100T15
1/2 CAGE PARTITION

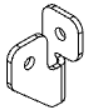

3DIV572151
DIVIDER BRACKET

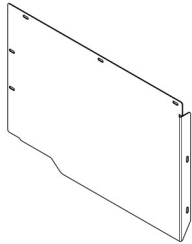

3PAR582402
SEAT PROTECTOR



3DIV582402
CNTR SEAT BRACKET



3DIV582404
BOTTOM BARRIER BRACKET

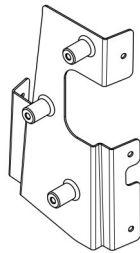

3P5818-02P
B-PILLAR BRACKET



3DIV582406
LOWER FILL PANEL

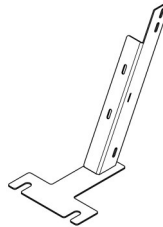

3PAR582401
CENTER SUPPORT

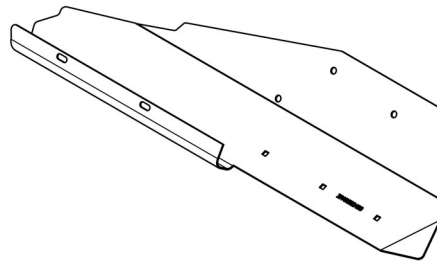

3PAR582400
MOUNTING BRACKET

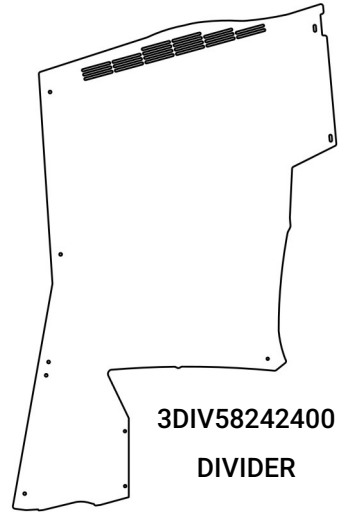

3DIV58242400
DIVIDER



3DIV582403
LOWER DIVIDER BRACKET

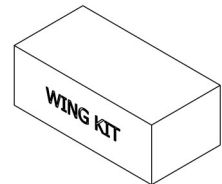

4W5818-03P
WING KIT

I. Read all instructions and refer to last page to ensure all parts were received

WARNING: *Locate All wiring, fuel lines, brake lines, coolant lines, or refrigerant lines before drilling any holes or installing any self-drilling fasteners.*

NOTE: BARRIER MUST BE INSTALLED FIRST

II. Partition B-Pillar Bracket Installation

- A. Remove passenger B-Pillar trim to access the sheet metal body. After trim is removed, position the B-Pillar Bracket [3P5818-02P] in location and mark the 5 holes to drill a pilot (use a 3/16" drill bit) for the self-tapping screws [3x162]. The b-pillar bracket is located when the top edge of bracket butts up against the bottom edge of the upper b-pillar trim.
- B. Use the b-pillar template supplied on the last page to mark the three holes in the b-pillar trim and drill out the 1" holes for the standoffs. Re-install trim.

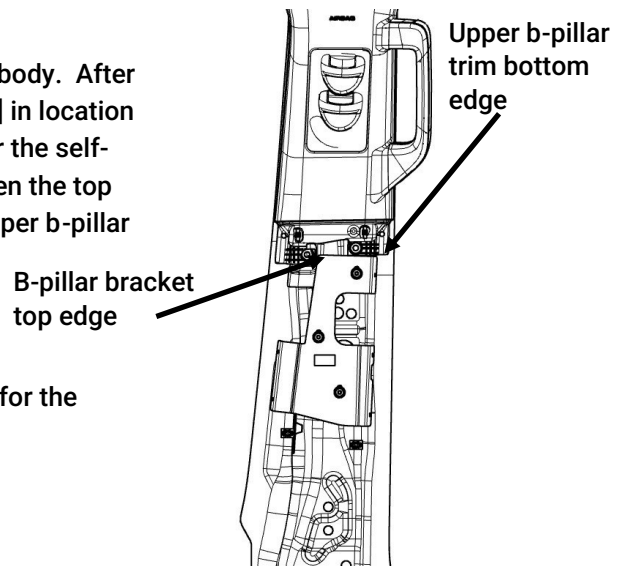

III. Partition Mounting Brackets

- A. With the b-pillar bracket and trim installed the mounting bracket [3PAR582400] can be installed.
- B. Use the three [3x149] button head socket cap screws to bolt the mounting bracket to the b-pillar bracket. Leave screws loose until the partition is installed.
- C. The Center Support [3PAR582401] is next. Loosen the two OEM console bolts in-between the front seats and slide the forks under the bracket. Tighten bolts. See below

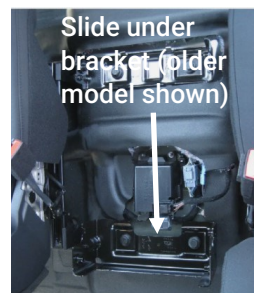
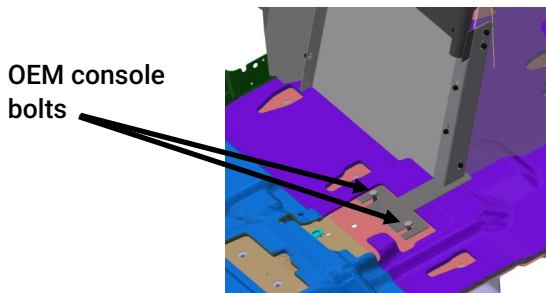

IV. Half Cage Installation

NOTE: ALL BOLTS IN THE HALF CAGE AND DIVIDER INSTALLATION SHOULD HAVE THE BUTTON HEAD FACING THE PRISONER CELL

- A. Place the half cage partition [4P1000T15] in the vehicle and bolt [3x36] screws and [3x16Z] whiz nuts to the mounting bracket [3PAR582400] and the center support [3PAR582401]. The mounting points are slotted, make sure to lift the partition tight to the ceiling while securing bolts.

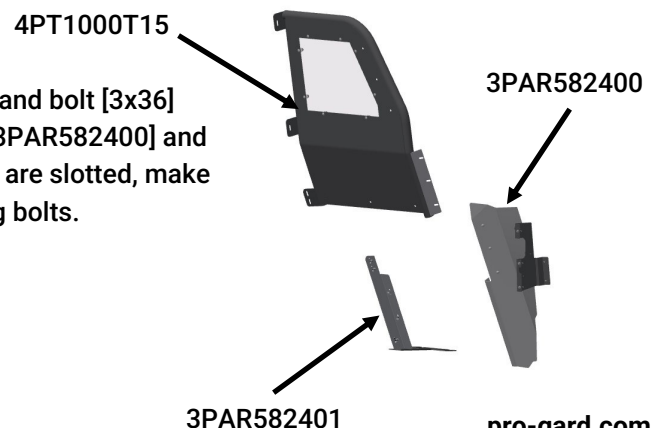

pro-gard.com
800.480.6680

- A. Attach the seat protector [3PAR582402] from the backside of the partition. Align with the partition, mounting bracket, and center support holes. Bolt together with [3x36] and [3x16Z] whiz nuts. Tighten the screws left loose in Section III, part B

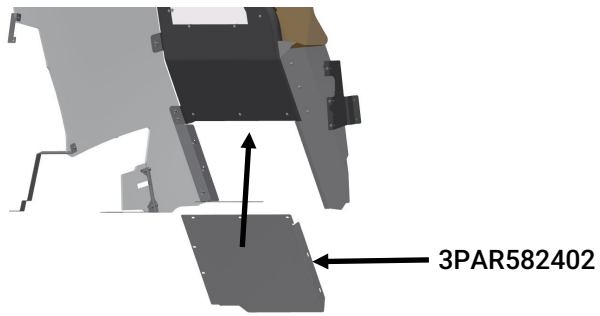

V. Divider Installation

- A. Install the Divider Bracket [3DIV572151] to the top of the barrier. This will install on top of the barrier wing.

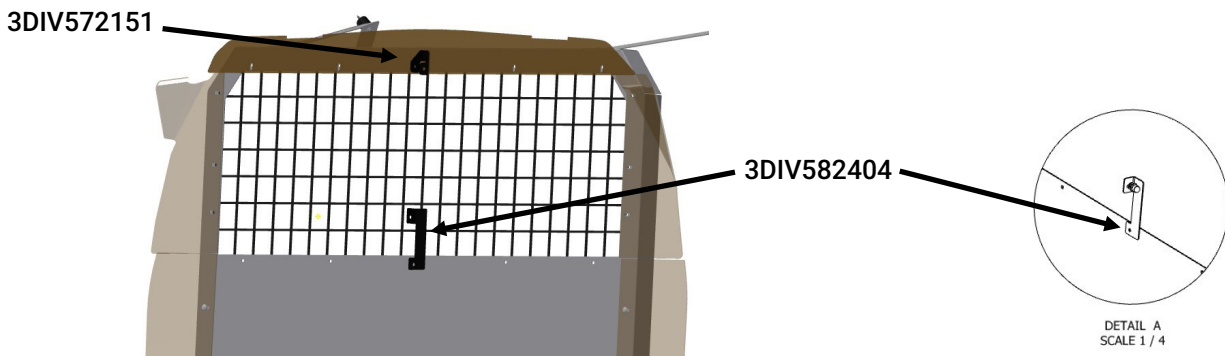

- B. Install the Bottom Barrier Bracket [3DIV582404] to the center hole.

- C. Remove the 6 OEM bolts holding the second row, center seat, down. Slide the Poly Joint Bracket [3DIV582403] under the front driver side bolt. Reinstall the 6 OEM bolts.



- D. Slide the drivers side, second row seat all the way forward. Remove the two rear seat bolts. Install the Center Seat Bracket [3DIV582402] by lifting on the rear of the seat and rotating bracket into place and under the inboard seat rail. See below.

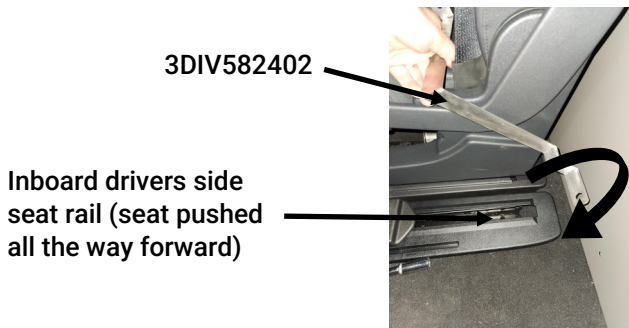

If it is still a tight fit, loosen the front seat bolts. Make sure you don't back the bolts out far enough they interfere with the slide (you will need to slide it forward again to access rear bolt). Line the bolt hole in the bracket up with the inboard OEM seat mount points and reinstall the inboard and outboard bolts. Tighten front bolts if loosened.



- E. Place the Lower Fill Panel [3DIV582406] under the seat with the slide lever in the notch. See below.

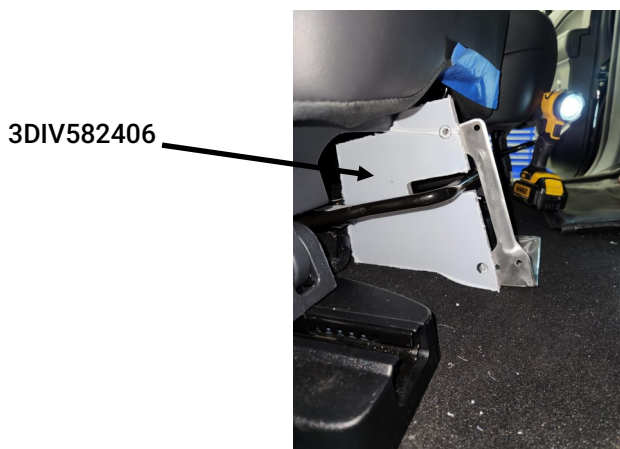

- F. Remove the head rest if applicable
- G. Bring the Divider [3DIV582400] in through the passenger side. Its easiest to bring the rear edge into place and rotate the front edge from passenger side to drivers side. When placing the rear edge, place in the middle of headrest post holes. The divider will fit tight against the partition, it may be necessary to put some pressure towards the front of the vehicle on the partition. This will allow you to clear the button heads on the previously installed partition carriage bolts.

H. The divider should sit outboard of all brackets.

I. Bolt the divider down with (12) [3x82] carriage bolts and [3x16Z] whiz nuts. Make sure to attach the lower fill panel.

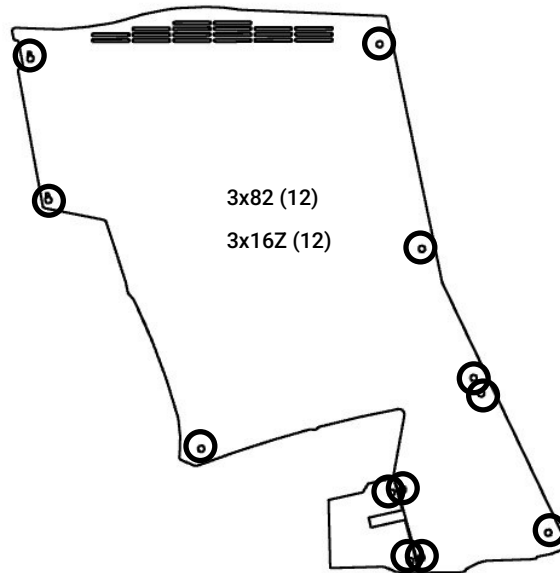

VI. Cap it off

A. Place the black plastic caps [3x145] on all exposed whiz nuts.

Installation complete

If you have any problems with this installation or have any questions please call (800-480-6680)

PARTS LIST

ITEM	QTY	PART NUMBER	DESCRIPTION
1	1	3DIV582400	EXPEDITION P1000 DIVIDER
2	1	3DIV582406	LOWER FILL PANEL
3	1	3DRP581800	ABS DOOR PANEL, PASS. SIDE
4	1	3DRP581801	ABS DOOR PANEL, DRIVER SIDE
5	1	3LEP582402	SEAT PROTECTOR, 58P1000
6	1	4BK5818	BARRIER KIT EXPD 18
7	1	4B5102XP	CARGO BARRIER, POLYCARB
8	1	4DRP58102	EXPD DOOR PANEL HARDWARE KIT
9	1	4PAK581800	EXPD P1000 PARTITION KIT
10	1	4P1000T15	PARTITION PRO-CELL TAH 15
11	1	WBPS8EXPD18	WINDOW BAR POLY ABS EXPD 18
12	1	WKS5818PRO	EXPD PRO CELL WING KIT
13	1	W58BEXPD	BARRIER WING KIT EXPD 18

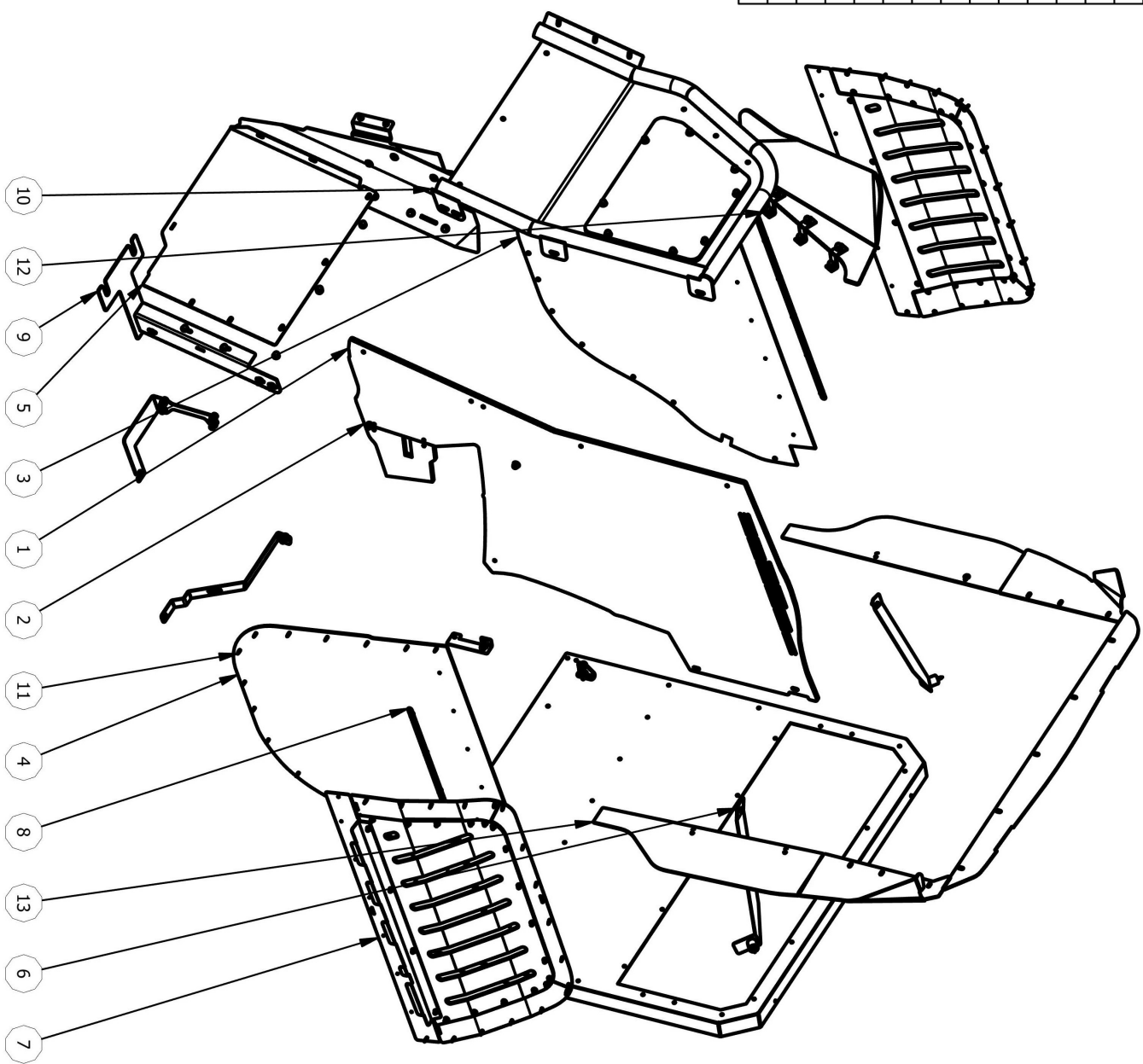

B PILLAR TEMPLATE INSTRUCTIONS:

1. USING TEMPLATE ON NEXT PAGE, CUT AWAY HATCHED AREA.
2. REMOVE B PILLAR TRIM AND ALIGN TEMPLATE AS SHOWN BELOW (PASS. SIDE SHOWN)
3. CENTER PUNCH 3 HOLE LOCATIONS THRU TEMPLATE AND DRILL/CUT 1 1/8" DIA. HOLE.
4. REINSTALL TRIM PANEL OVER INSTALLED B PILLAR BRACKET.
5. FLIP TEMPLATE OVER TO COMPLETE DRIVERS SIDE AS NEEDED.

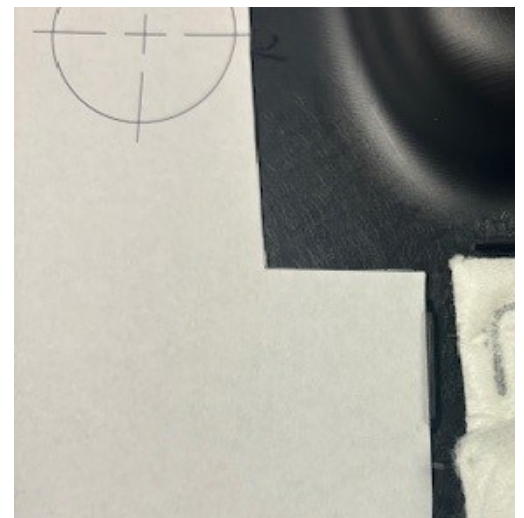
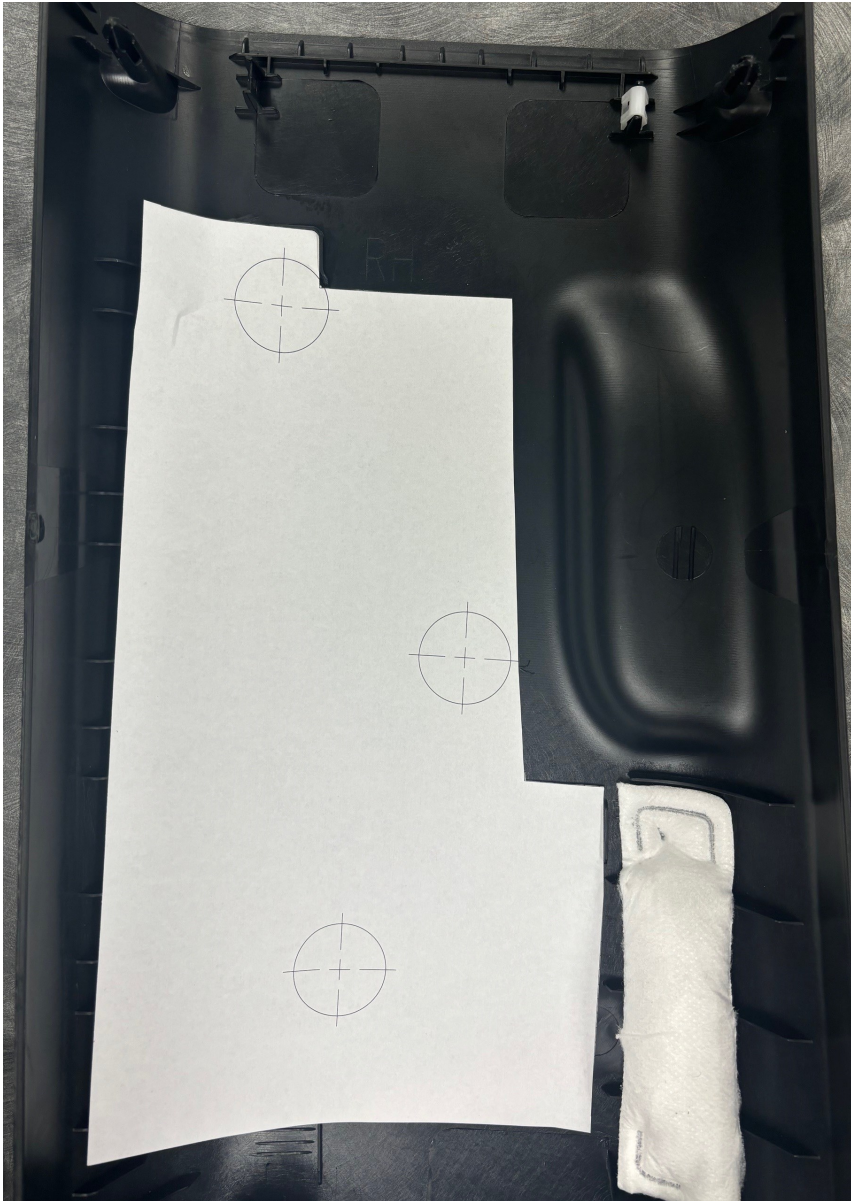

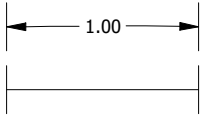
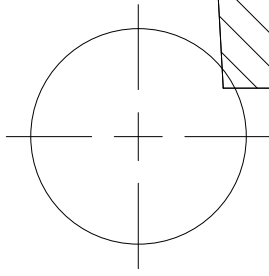

CHECK SCALE
DO NOT SCALE PAGE
WHEN PRINTING FROM PDF.

