

# **INSTALLATION GUIDE**

**2021 - CURRENT  
CHEVY TAHOE  
CARGO STORAGE FLOOR  
CSF57T21**

**Pro-gard**<sup>™</sup>  
PRODUCTS LLC.

**STRONG. RELIABLE. SECURE.**

**THESE COMPONENTS ARE REQUIRED  
TO INSTALL THE CARGO STORAGE FLOOR**



**4STK572120  
(CSF Kit)**

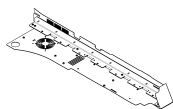

**4STF572102  
(Driver Side Panel Assy)**

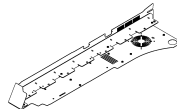

**4STF572103  
(Passenger Side Panel Assy)**

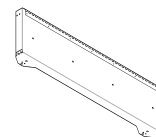

**4STF572105  
(Front Panel Assy)**

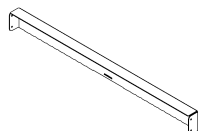

**3STF572130  
(Rear Panel Weldment)**

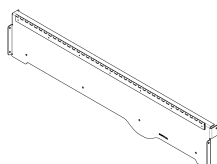

**4STF572121  
(Front Mid Panel Assy)**

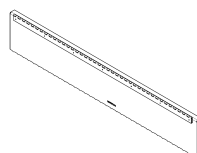

**4STF572131  
(Rear Mid Panel Assy)**

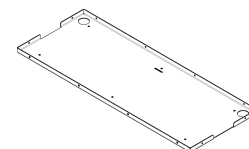

**4STF572107  
(Electronics Floor Assy)**

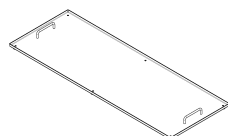

**4STF572110  
(Electronics Tray)**

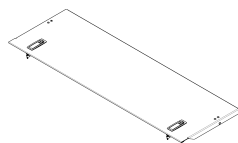

**4STF572142  
(Rear Locking Cargo Lid)**



**4STF572141  
(Mid Cargo Lid Assy)**

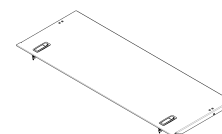

**4STF572144  
(Front Cargo Lid Assy)**

**I. The following tools will be required to complete the installation**

- |                   |                          |
|-------------------|--------------------------|
| A. M10 hex drive  | E. #14 socket            |
| B. #6 hex drive   | F. Phillips screw driver |
| C. #10 hex drive  | G. 7/16" Drill Bit       |
| D. 1/4" hex drive |                          |

**II. Read all instructions and refer to the Parts List to ensure all parts were received.**

---

**WARNING:** *Locate all wiring, fuel lines, brake lines, coolant lines, and refrigerant lines before drilling any holes or installing any self-drilling fasteners.*

---

**III. Vehicle Preparation**

**A. Remove OEM Components**

1. Pull up floor mat so that mounting locations for brackets is exposed.
2. Remove OEM M10 bolts where front brackets and front panel will mount as shown in Figure 1a.

**B. Modify OEM Components**

1. Locate the black ABS hole template. Using the removed OEM M10 bolts, secure the template to the driver side front bracket mounting holes as shown in Figure 1b. Mark the rear bracket holes for drilling. Drill 7/16" holes in floor for mounting of rear brackets. Repeat using the same template for passenger side (template will be flipped over)
2. Cut slots in the floor mat as needed to allow for bracket installations.

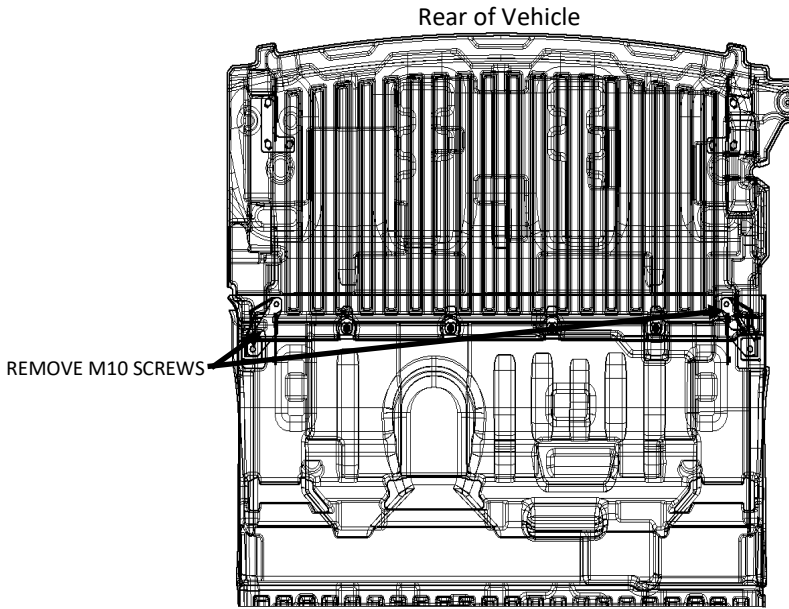

Figure

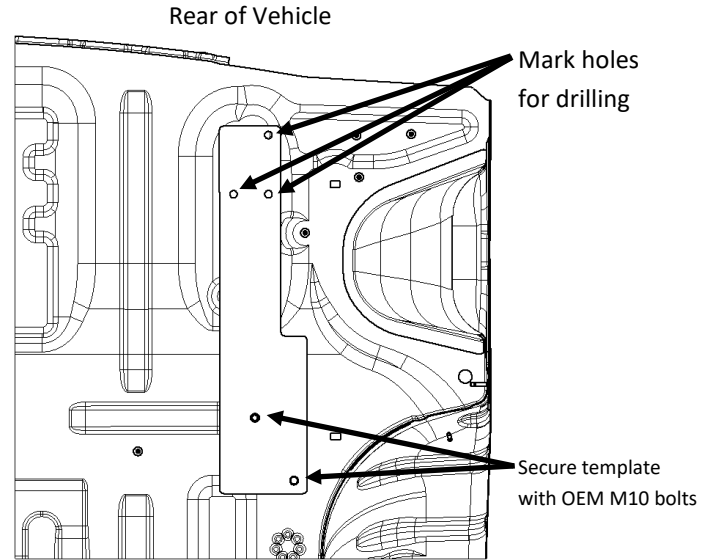

Figure 1b

## IV. Bracket & Side Installation

**NOTE:** *If Barrier is installed already or being installed, front brackets mount on top of the barrier brackets.*

### A. Install the Front brackets

1. Locate Front Driver Side Bracket [3STF572122], Front Passenger Side Bracket [3STF572123] and (4) OEM M10 bolts that were removed.
2. Place Front Driver Side Bracket over mounting holes. Reinstall OEM bolts and torque to factory specifications using M10 hex drive.
3. Repeat Step 2 for Front Passenger Side Bracket.

### B. Install the Rear Brackets

1. Locate Rear Driver Side Bracket [3STF572125], Rear Passenger Side Bracket [3STF572124], (2) bracket gaskets, (2) Rear Bracket Sandwich Plates [3STF572128], and (6) [3X601] 3/8-16 serrated flange hex nuts.
2. Place Rear Driver Side Bracket through the mounting holes in floor. From the underside of vehicle place bracket gasket, then Rear Bracket Sandwich Plate up onto bolts. Secure with serrated flange hex nuts as shown in Figure 2.
3. Repeat Step 2 for Rear Passenger Side Bracket.

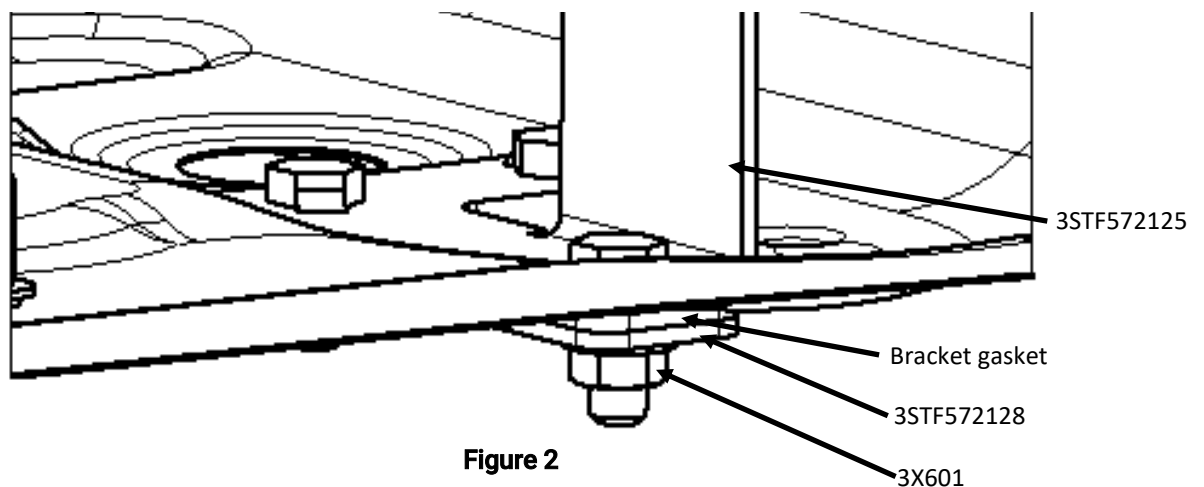

Figure 2

## V. Sides, Front, and Rear Installation

### A. Side Panels Installation

1. Locate Drivers Side Panel Assembly [4STF572102], Passenger Side Panel Assembly [4STF572103], and (12) [3X283] 1/4-20x1 Button Head Socket Cap Screws.
2. Mount Drivers Side Panel Assembly to brackets as shown in Figure 3 with 1/4" hex drive. Screws should be mounted with the head facing the interior.
3. Repeat step 2 for Passenger Side Panel Assembly.

### B. Front Panel Installation

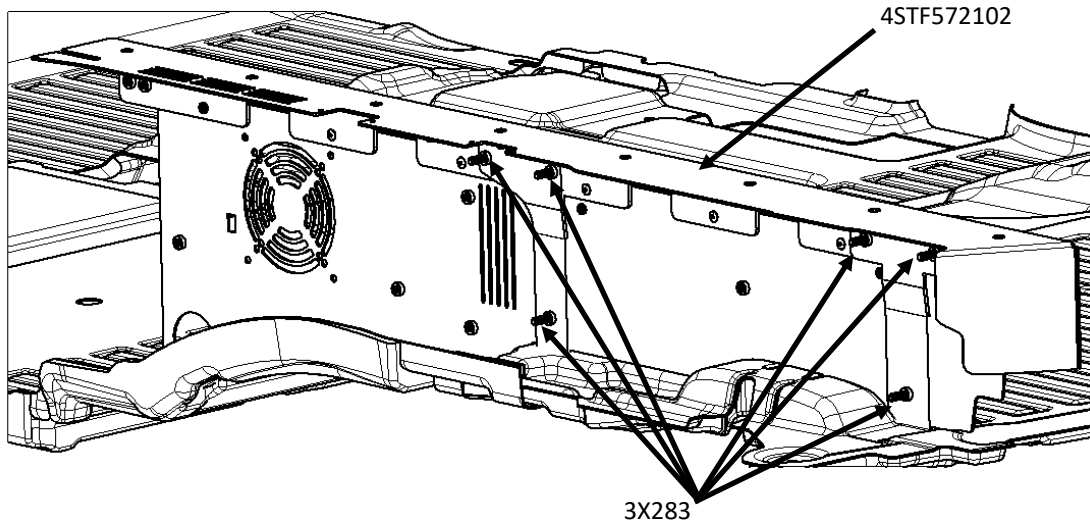

Figure 3

**NOTE:** *If Barrier is installed already or being installed, front panel mounts on top of the barrier brackets using existing barrier hardware.*

1. Locate Front Panel Assembly [4STF572105], (4) [3X283] 1/4-20x1 Button Head Socket Cap Screws, (4) [3X47] #14 x 1-1/2" Self Drilling Hex Head Screws, and (2) OEM M10 bolts that were removed at the start.
2. Mount Front Panel Assembly to Driver Side Panel Assy with Button Head Socket Cap Screws using 1/4" hex drive as shown in Figure 4a. Repeat for attaching to Passenger Side Panel Assy.
3. Reinstall OEM M10 bolts securing bottom of front panel to floor on both driver and passenger side using M10 hex drive. Install Self Drilling Hex Head screws with #14 socket on driver side as shown in Figure 4b. Repeat for passenger side.

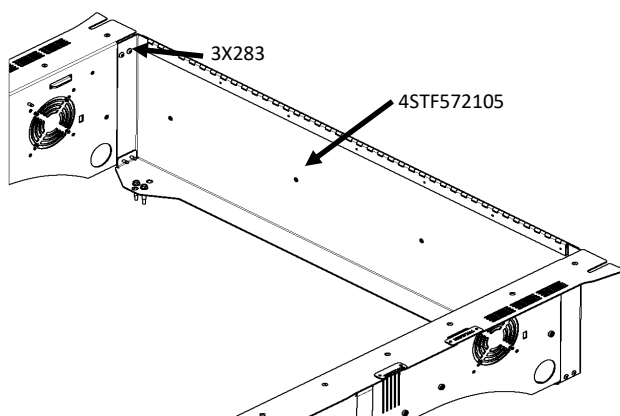

Figure 4a

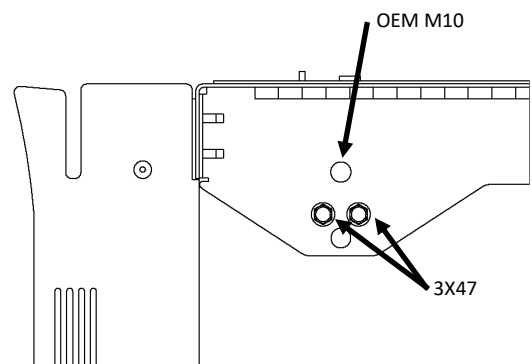

Figure 4b

## C. Rear Panels Installation

1. Locate the Rear Panel Weldment [3STF572130] and (4) [3X283] 1/4-20x1 Button Head Socket Cap Screws.
2. Mount Rear Panel Weldment to Driver Side Panel Assy with 1/4" hex drive as shown in Figure 5. Repeat for attaching to Passenger Side Panel Assy.

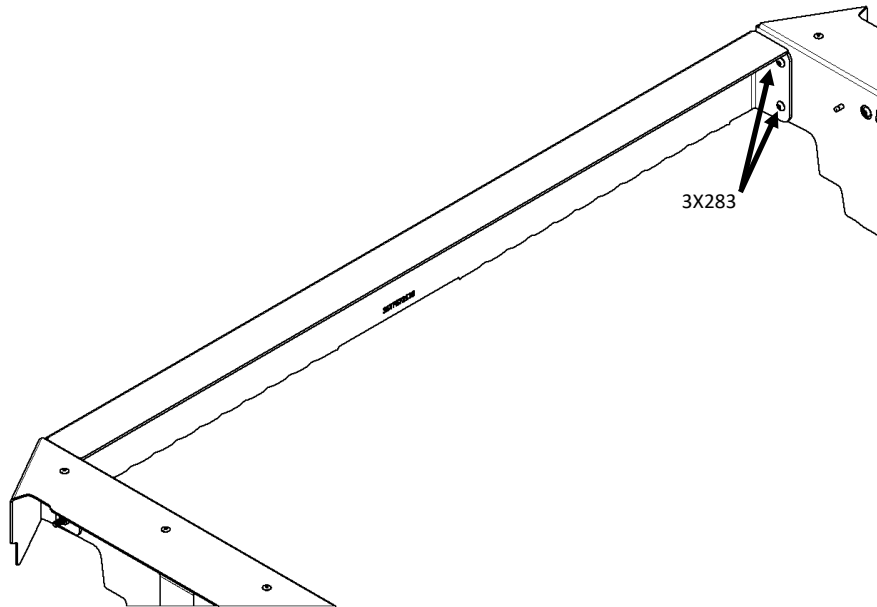

Figure 5

## VI. Mid Panels and Electronics Tray Installation

### A. Electronics Floor Assembly Installation

1. Locate the Electronics Floor Assembly [4STF5725107], (8) [3X283] 1/4-20x1 Button Head Socket Cap Screws, and (4) [2422] 2" Grommets.
2. Prior to floor installation, install a grommet in the Driver and Passenger Side Panel Assemblies in the location shown in Figure 6a.
3. Mount Electronics Floor Assembly to Front Panel Assembly, Driver Side Panel Assy, and Passenger Side Panel Assembly with 1/4" hex drive as shown in Figure 6b.
4. Install remaining grommets in Electronics Floor Assembly.

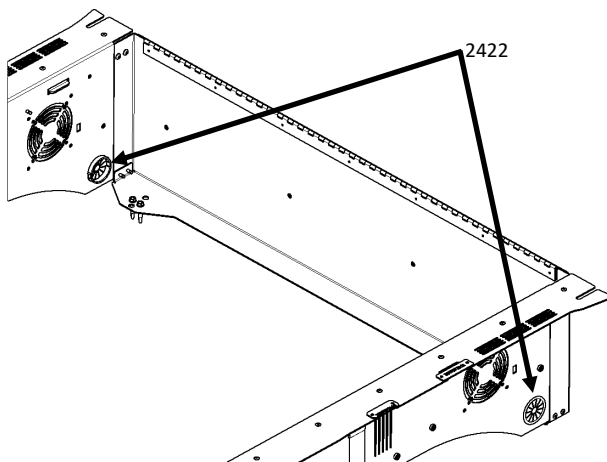

Figure 6a

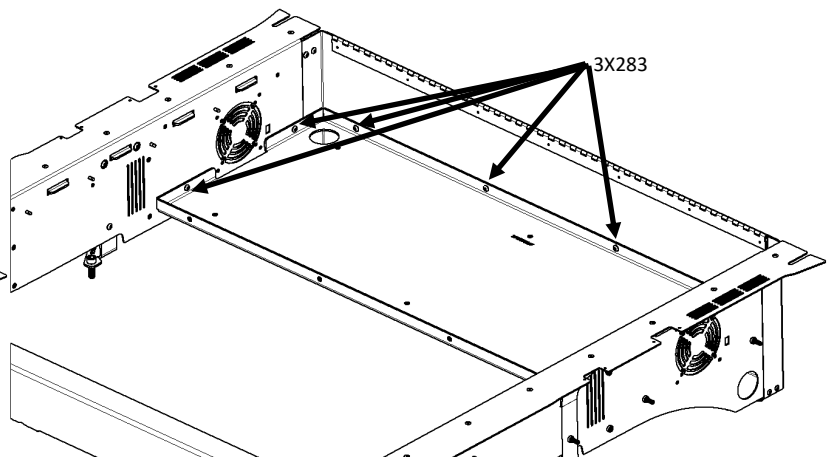

Figure 6b

## B. Front Mid Panel Installation

1. Locate the Front Mid Panel Assembly [4STF5725121] and (10) [3X283] 1/4-20x1 Button Head Socket Cap Screws.
2. Mount Front Mid Panel Assembly to Driver Side Panel Assy with 1/4" hex drive as shown in Figure 7. Repeat for attaching to Passenger Side Panel Assembly and Electronics Floor Assembly.

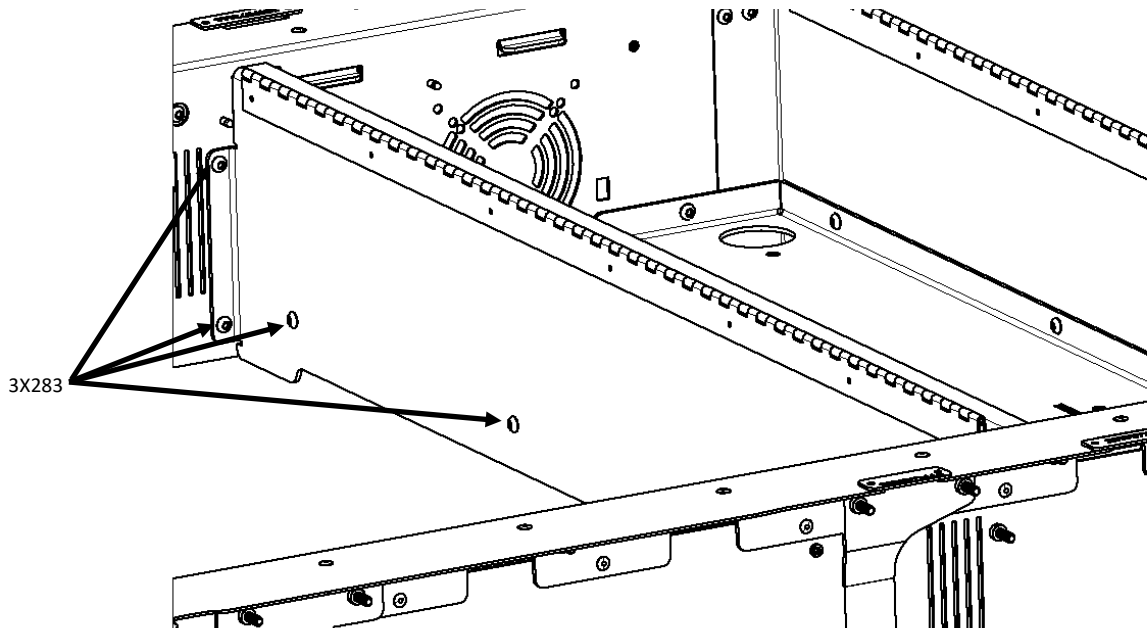

Figure 7

## C. Rear Mid Panel Installation

1. Locate the Rear Mid Panel Assembly [4STF5725131] and (6) [3X283] 1/4-20x1 Button Head Socket Cap Screws.
2. Mount Front Mid Panel Assembly to Driver Side Panel Assy with 1/4" hex drive as shown in Figure 8. Repeat for attaching to Passenger Side Panel Assy.

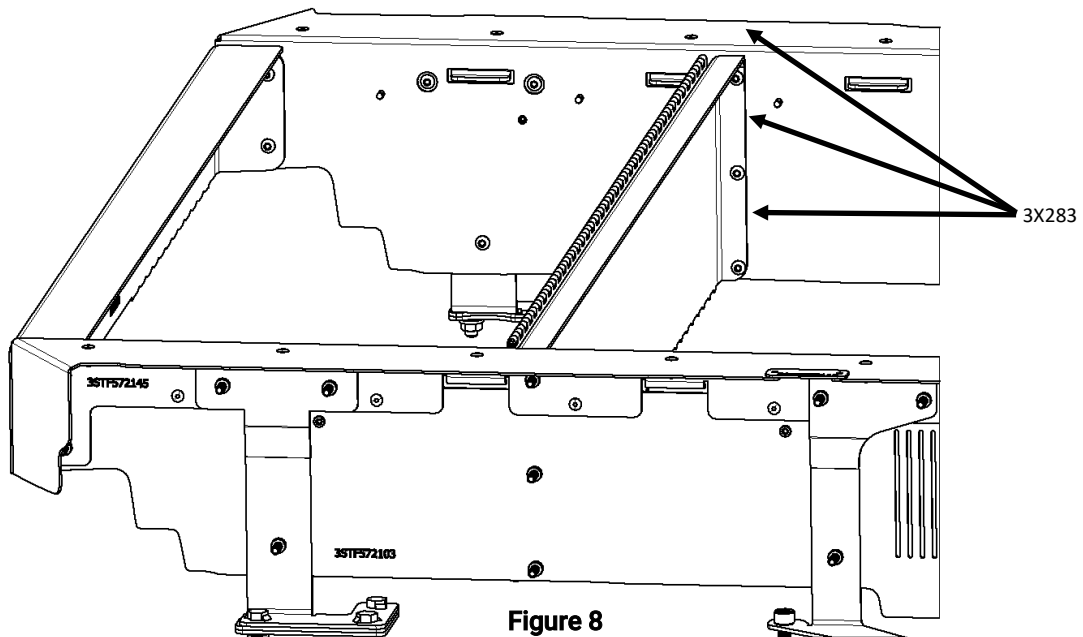

Figure 8

## D. Electronics tray installation

1. Locate the Electronics Tray [4STF572110] and (6) [3X07] 1/4-20 Philips Head Truss Screws.
2. Mount Electronics Tray on top of Electronics floor using Philips Head Screwdriver as shown in Figure 9.

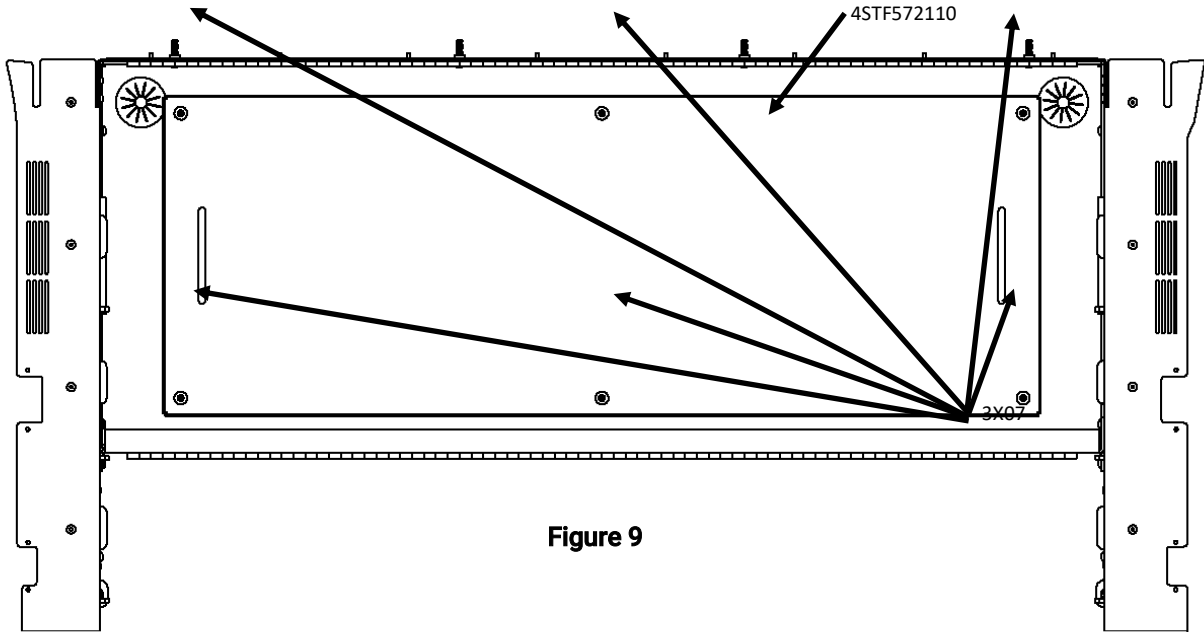

Figure 9

## Cover Plates Installation

3. Locate the Rear Driver Side Cover Plate [3STF572114], Rear Passenger Side Cover Plate [3STF572116], Front Cover Plates [3STF572111], and (8) [3X299] #8 X 3/4 Self Drilling Philips Head Screws.
4. Install Cover Plates as shown in Figure 10. If vehicle has Cargo Security Cover, Rear Cover Plates will not be used.

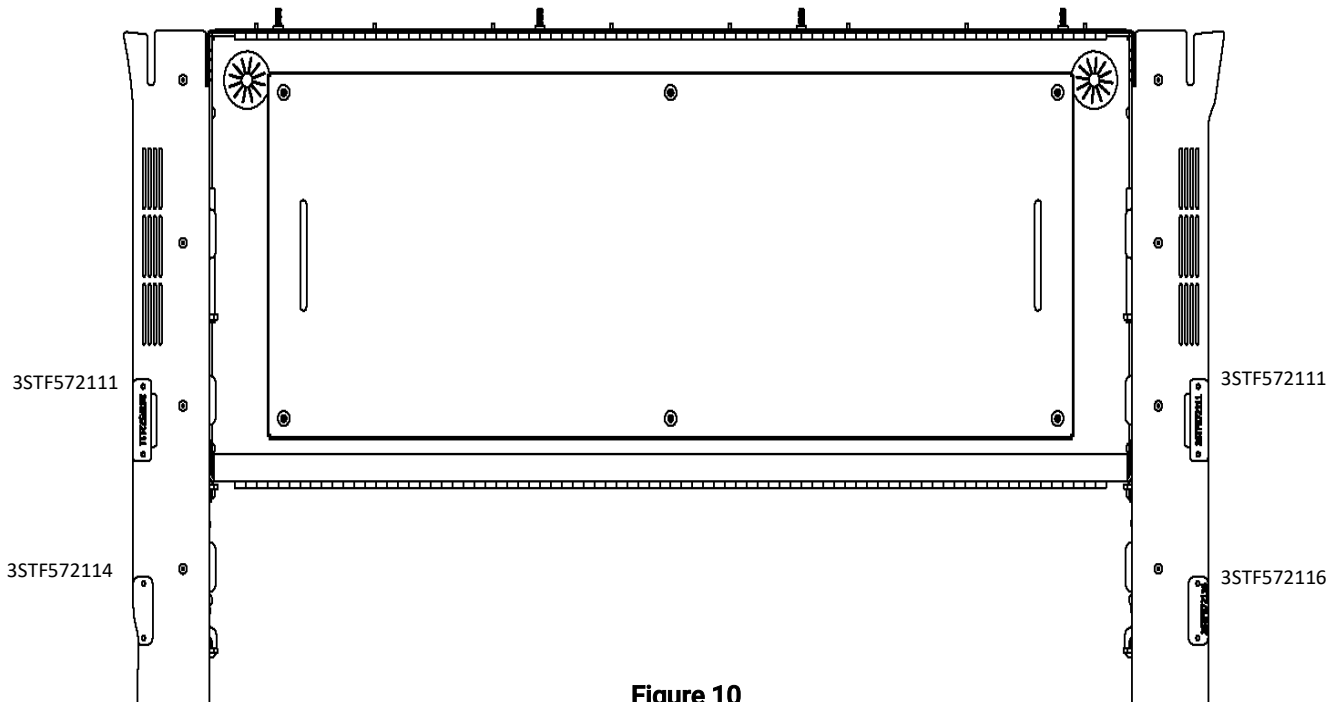

Figure 10

## VII. Door Installation

### A. Door Hinge Install

1. Locate (6) Support Hinges [SE-S55N], (6) Aluminum Lid Stay Spacers [3STF572135], and (6) [3X314] 10-24 X 1.25" Button Socket Head Cap Screws.
2. Position Spacer between the Support Hinge and the Side Panel. Secure the short leg of the Support Hinge and Spacer to the wall with a Button Head Socket Cap Screw using #10 hex drive as shown in Figure 11. Notice the Hinged is pointed towards the front of the vehicle.

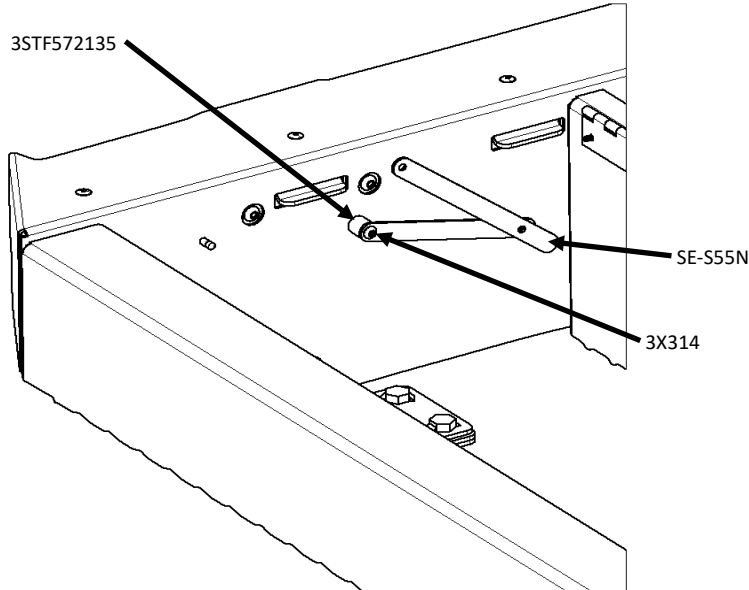

Figure 11

3. Repeat to attach Hinge Supports to both driver and passenger side for the rear and middle compartments, making sure to attach the short leg of the Hinge Support to the wall
4. For the Hinge Supports in the forward compartment, the short leg still mounts to the wall, but the hinge needs to be pointed towards the rear of the vehicle instead of towards the front. This is shown in Figure 12.

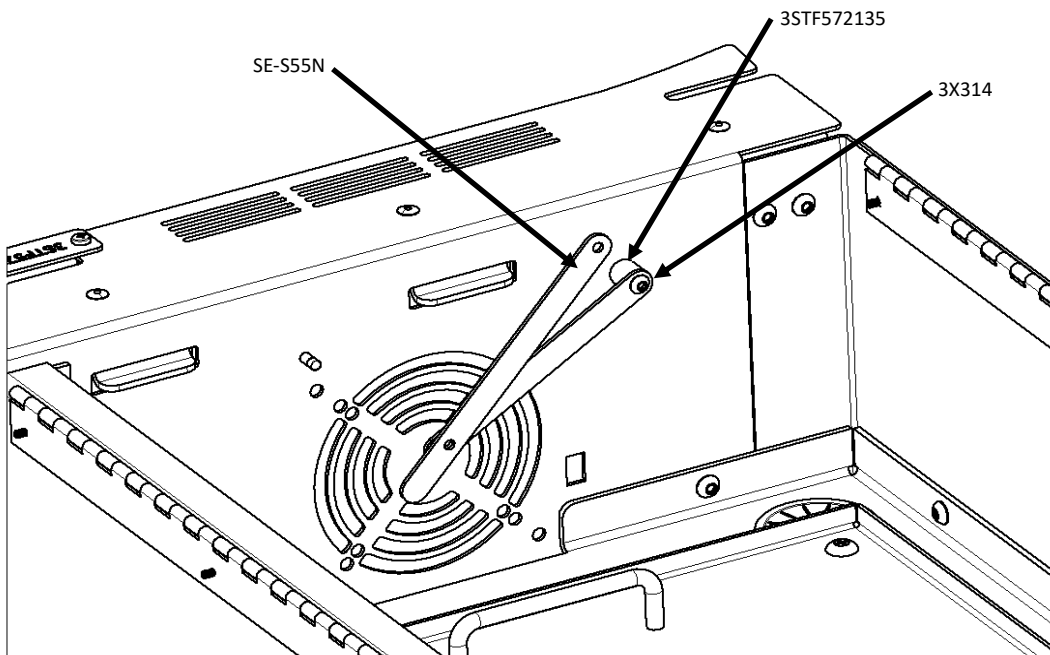

Figure 12



## B. Door Install

1. Locate Rear Locking Cargo Lid Assembly [4STF572142], Mid Cargo Lid Assembly [4STF572141], Front Cargo Lid Assembly [4STF572144], and (21) [3X315] 6-32 X 5/16 Flat Head Socket Cap Screws.
2. Attach Front Cargo Lid Assembly to Front Panel Assembly with Flat Head Socket Cap Screws using 5/64 hex drive. Repeat to attach Mid Cargo Lid Assembly to Front Mid Panel Assembly and Rear Locking Cargo Lid Assembly to Rear Mid Panel Assembly. Attached Panels will look like Figure 13.

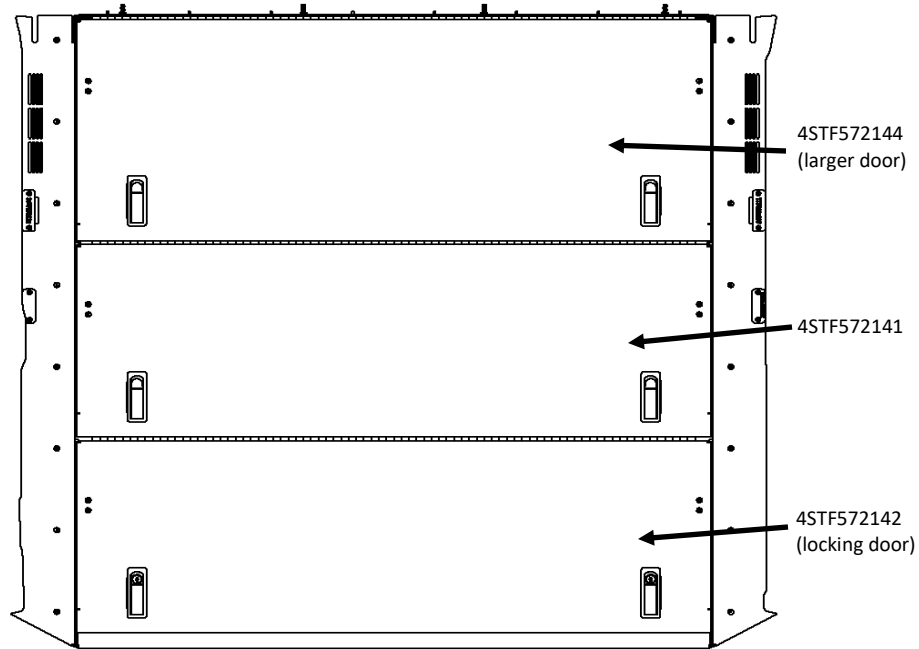

Figure 13

## C. Attach Support Hinges to Doors

1. Locate (6) [3X313] 10-24 X 1/2" Button Socket Head Cap Screws and (6) [3X312] 10-24 Nylon Locknut.
2. Attach the long leg of the Support Hinge to the bracket on the underside of the Cargo Lid Assembly with a screw and locknut using a #10 hex drive as shown in Figure 14. Repeat this until all 6 Support Hinges are attached to the lids.

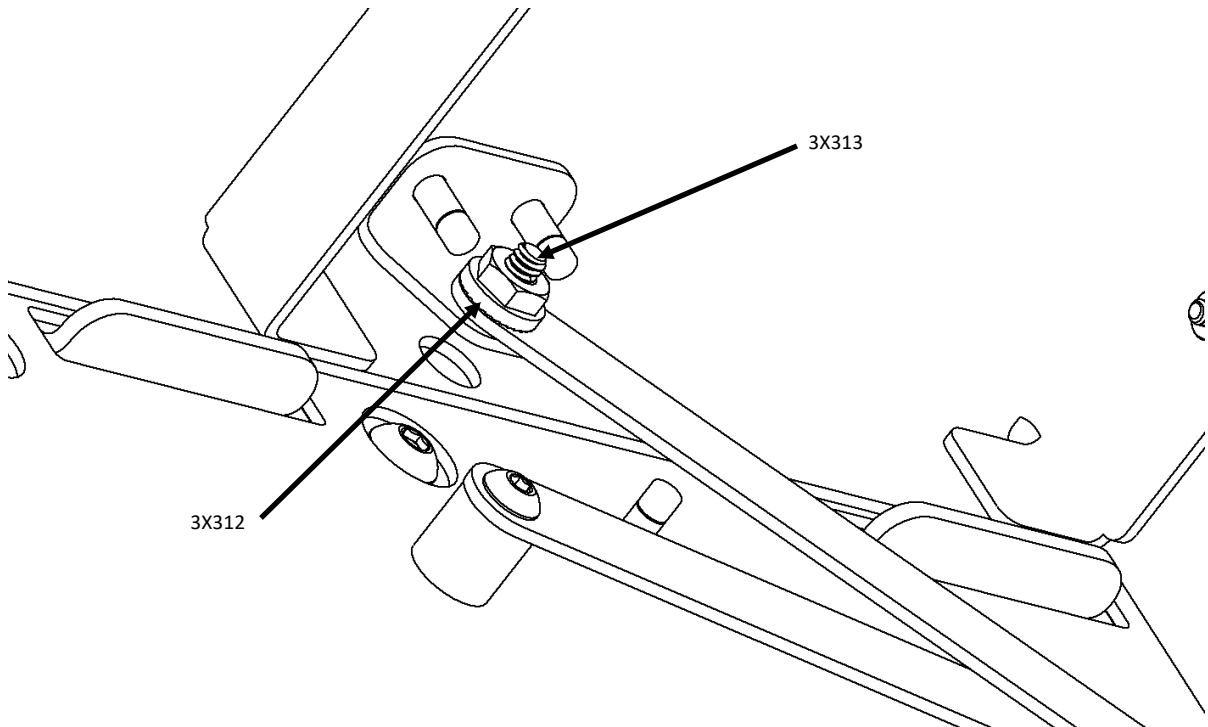

Figure 14

## **IX. Final Steps**

- A. Ensure all fasteners are tight.
- B. Adjust door clamps to ensure doors can open/close properly

### **Installation complete**

If you have any problems with this installation or have any questions please call (800-480-6680) and ask for technical assistance.

PARTS LIST		
ITEM	QTY	DESCRIPTION
1	1	ELECTRONICS FLOOR ASSEMBLY
2	1	REAR PANEL WELDMENT
3	1	DRIVER SIDE PANEL ASSEMBLY
4	1	PASSENGER SIDE PANEL ASSEMBLY
5	1	FRONT PANEL ASSEMBLY
6	1	ELECTRONICS TRAY
7	1	FRONT MID PANEL ASSEMBLY
8	1	REAR MID PANEL ASSEMBLY
9	1	MID CARGO LID ASSEMBLY
10	1	REAR, LOCKING CARGO LID ASSEMBLY
11	1	FRONT CARGO LID ASSEMBLY
12	1	STORAGE FLOOR HARDWARE KIT

NOTE: LIDS TRANSPARENT

45TK572120 STORAGE FLOOR KIT BOM		
ITEM	QTY	DESCRIPTION
1	1	CSF HARDWARE KIT 1
2	1	CSF HARDWARE KIT 3
3	2	REAR BRACKET SANDWICH PLATE
4	2	REAR BRACKET GASKET
5	1	CSF HARDWARE KIT 2
6	1	DRIVER MIDDLE BRACKET WELDMENT
7	1	PASSENGER MIDDLE BRACKET WELDMENT
8	1	PASSENGER REAR BRACKET WELDMENT
9	1	DRIVER REAR BRACKET WELDMENT

45TK572121 HARDWARE KIT 1 BOM		
ITEM	QTY	DESCRIPTION
1	12	1/4-20X1 BHSCS BO SS
2	6	3/8-16 SERRATED FLANGE HEX NUT BLACK ZINC
3	2	M10-1.3X30 SHCS ZINC

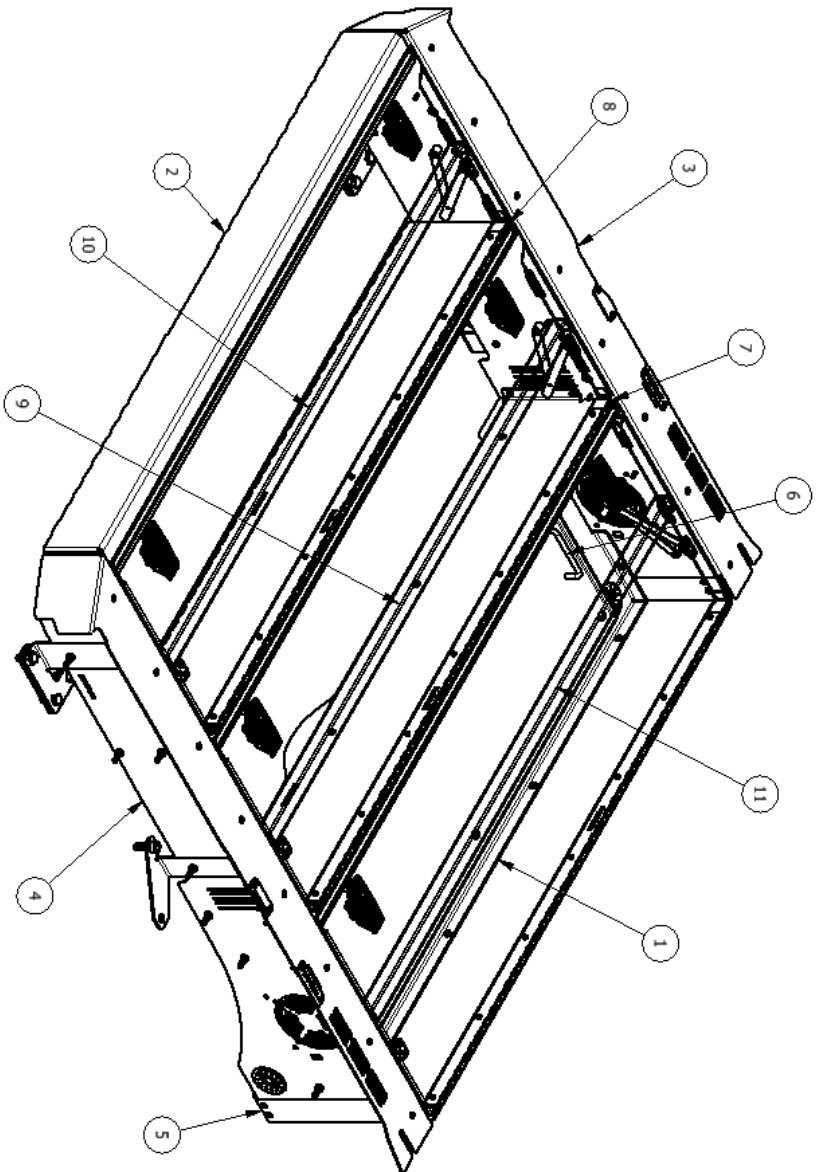

45TK572102 HARDWARE KIT 2 BOM		
ITEM	QTY	DESCRIPTION
1	4	3X47 #14 X 1-1/2" SELF DRILLING HEX HEAD SCREW
2	8	3X299 #8 X 3/4" SELF DRILLING PHILLIPS HEAD, BO
3	6	3X07 1/4-20 X 1-1/2 PHIL TRUSS HD MS
4	4	2422 2" NYLON EXPANDABLE LOCKING GROMMET
5	32	3X283 1/4-20X1 BHSCS BO SS
6	2	35TF572111 BARRIER SUPPORT COVER PLATE
7	1	35TF572116 PASSENGER NO CSC COVER PLATE
8	1	35TF572114 DRIVER NO CSC COVER PLATE

45TK572103 HARDWARE KIT 3 BOM		
ITEM	QTY	DESCRIPTION
1	6	35TF572135 ALUMINUM LID STAY SPACER
2	6	3X312 10-24 NYLON LOCKNUT
3	6	3X313 10-24 X 1/2 BHSCS
4	6	3X314 10-24 X 1 1/4 BHSCS
5	21	3X315 6-32 X 5/16 SS FLAT-HEAD SCKT CAP SCREW
6	6	SE-555N SE-555N HINGE