

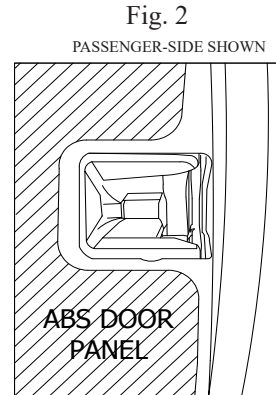



## V. ABS Door Panel Installation

- A. Place the window seal back onto the door frame as though the door panel was there.
- B. Next, place the ABS Door Panel against the door and align. Once the panel fits flush around the door latch (see Fig. 2), install one #8 x 5/8 to both sides of the door. Ensure that the side of the ABS Door panel closest to the door hinges is flush with the door.
- C. Attach the remainder of the door panel, from top to bottom with the supplied screws, Type A-self tapping, sometimes it is necessary to drill a 3/32" pilot. (See Fig. 3)



## VI. Window Armor Installation

- A. Raise the Window Armor above the ABS door panel. Then lower the Window Armor so that the ABS door panel slides into the Window Armor's lower bracket. Ensure that the retaining flanges on lower bracket fit onto the window seal correctly.
- B. Center the outside of the metal mounting frame on the door from side to side. While applying pressure down on the Window Armor, ensure that the outer side brackets bottom out onto the ABS door panel.
- C. If the side brackets do not touch the abs panel then it is necessary to mark the rubber window seal where the flanges hit. Remove the Window Armor. Using a razor knife, cut slits through only the first layer of the window seal. Now reinstall the Window Armor.
- D. Align the upper bracket of the Window Armor to the upper door frame, before securing.
- E. Install all screws from the bottom to the top of the Window Armor. Using the #8 x 5/8 self tapping screws. Followed by the remaining two lower screw locations in the lower bracket of the Window Armor. (See Fig. 4)

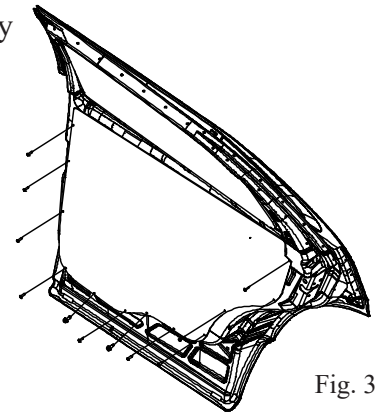
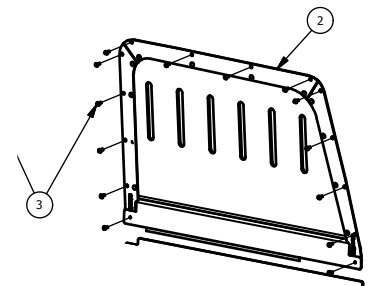

Fig. 4  
PASSENGER-SIDE SHOWN



## VII. Installation Complete

**If you have any problems with this installation than call the toll free number (800-480-6680) and ask for technical assistance.**

WBP57T15			
ITEM	QTY	PART NUMBER	DESCRIPTION
1	1	3WBP5715-D	WINDOW BAR POLY - DRIVER
2	1	3WBP5715-P	WINDOW BAR POLY -PASSENGER
4WBPHK5715			
ITEM	QTY	PART NUMBER	DESCRIPTION
3	28	3X72	8-32 X 5/8 PHIL PAN HD MS
DP57T15			
ITEM	QTY	PART NUMBER	DESCRIPTION
4	1	3DP5715-01D	ABS DOOR PANEL - DRIVER
5	1	3DP5715-01P	ABS DOOR PANEL - PASSENGER
4HKDP001			
ITEM	QTY	PART NUMBER	DESCRIPTION
6	36	3X72	8-32 X 5/8 PHIL PAN HD MS

