

**INSTALLATION GUIDE**  
WBP56C11  
POLYCARBONATE WINDOW BARRIERS  
AND DP56C11 ABS DOOR PANELS  
11 - CURRENT DODGE CHARGER

**Pro-gard**<sup>™</sup>  
PRODUCTS LLC.

**STRONG. RELIABLE. SECURE.**

**pro-gard.com**  
**800.480.6680**

THESE COMPONENTS ARE REQUIRED  
TO INSTALL THE PRO-GARD STEEL WINDOW ARMOR

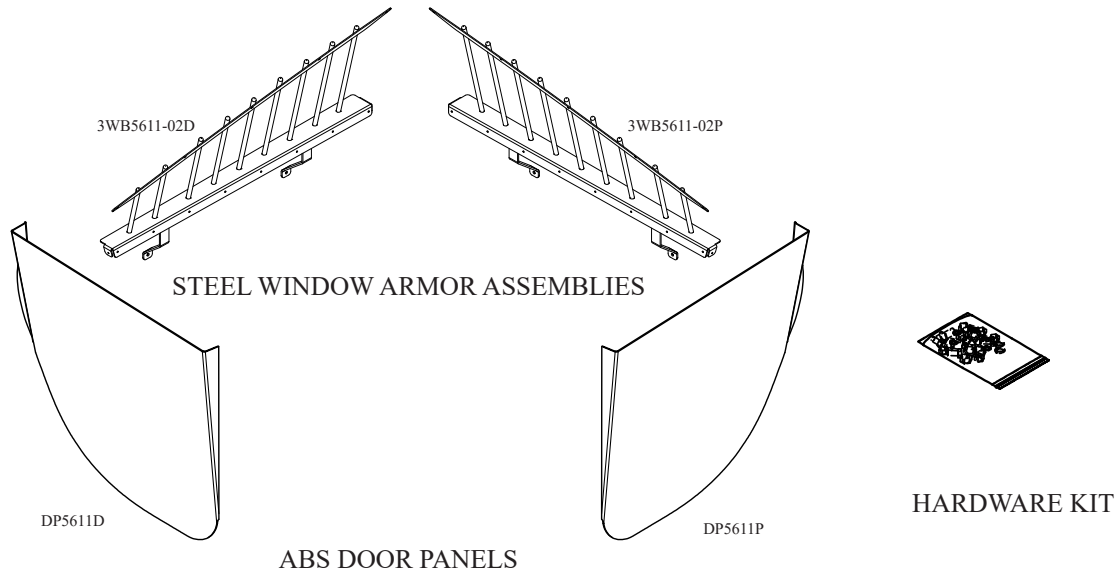

THIS WINDOW ARMOR IS ONLY USED WITH #DP56C11 ABS DOOR PANEL.  
Use #WBP56NPC11 with OEM door panel.

**I. Refer to the diagrams above to verify all parts were received.**

**II. The following tools will be required to complete the installation.**

1. Drill with standard #2 Philips driver
2. Drill bit 7/64" diameter
3. 10mm Socket Wrench

**III. Read all instructions carefully before starting the assembly process.**

**NOTE:** *Locate all Wiring, Fuel Lines, Brake Lines, and/or Cooling Lines before drilling holes or installing any Fasteners.*

**IV. OEM Door Panel Removal**

- A. Find the recess/keeper in the vertical face of the manual door lock knob, use a small screwdriver to pop the keeper out. The manual lock knob can now be removed.
- B. Find the cover plates behind both door handles, use a small screwdriver to remove.
- C. Remove the 6mm bolts from behind each using a 10mm nut driver.
- D. Starting at the bottom, locate and pry the plastic fasteners loose to remove OEM door panel from the door assembly.
- E. Disconnect the door latch cable from the door handle assembly.

- F. Remove the power window switch from the door panel.
- G. Remove the sound/moisture barrier from the inside of the door panel for reinstallation later.
- H. Secure the door latch cable to the door frame so it will not rattle.
- I. Make sure the power window switch is connected to the harness, protect it from moisture and secure the harness inside the door frame away from the window travel.
- J. Remove the manual door lock rod from its mount and remove.
- K. Reinstall the sound/moisture barrier on the inside face of the door.

### III. Window Armor Installation

- A. Remove the OEM rubber molding from the OEM Door Panel (See Fig. 2) and replace on to the vehicle door window frame. (See Fig. 2)
- B. With the OEM door panel removed, locate the upper bolts holding the window assembly to the door frame. Remove the outside and inside bolts. Place the Window Barrier on top of the rubber trim installed above. Align the mounting tabs with the holes in the window assembly. Using the OEM bolts removed previously, fasten the window armor to the vehicle door. (See Fig. 3)
- C. Center the outside of the metal mounting frame on the door front to back
- D. Install the lower screws at each side first, then work up each side installing the rest of the screws. The supplied screws (3X72) are a Type A-self tapping but sometimes it is necessary to drill a 7/64" pilot hole.

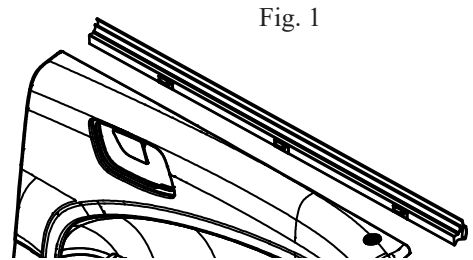

Fig. 1

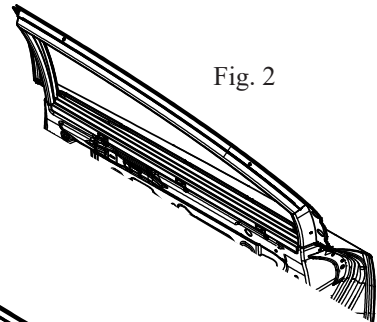

Fig. 2

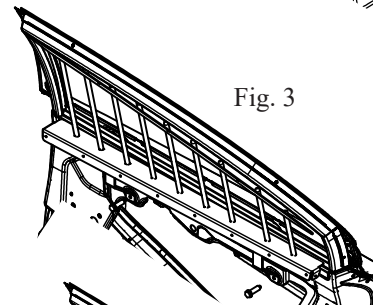

Fig. 3

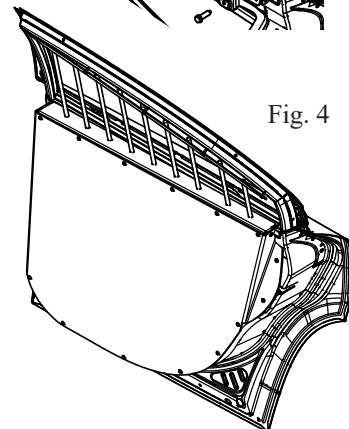

Fig. 4

### V. ABS Door Panel Installation

- A. Slide the ABS door panel over the window armor, align front to back for best fit. (See Fig. 4)
- B. Attach with (3X72) #8 x 5/8 self tapping screws.

### IV. Installation is now complete