

INSTALLATION GUIDE

WB54SIL16

**STEEL WINDOW ARMOR AND
ABS DOOR PANEL**

2016 - EARLY 2019 SILVERADO

Pro-gard[™]
PRODUCTS LLC.

STRONG | RELIABLE | SECURE

**pro-gard.com
800.480.6680**

THESE COMPONENTS ARE REQUIRED
TO INSTALL THE PRO-GARD STEEL WINDOW ARMOR

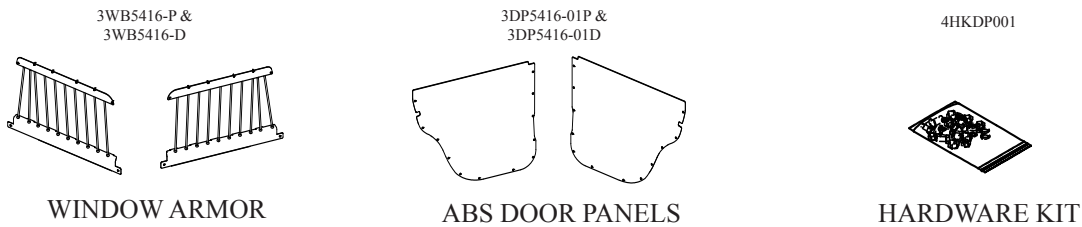

I. Refer to the diagram on the last page to verify all parts were received.

II. The following tools will be required to complete the installation.

1. Drill with standard #2 Philips driver
2. Drill bit 3/32" diameter

III. Read all instructions carefully before starting the assembly process.

NOTE: *Locate all wiring before drilling holes or installing any fasteners.*

IV. OEM Door Panel Removal

A. Remove the OEM door panel from the door frame. (See Fig. 1)

Note: Remove the window seal from door panel, this will be used before the window armor is installed.

B. Now remove the door speaker from the vehicle.

C. Next Push the large rubber grommet into the door shell, along with the wires. Also push in the door latch cable and lower the door lock rod out of the way.

D. Remove the power window switch from the door panel and reconnect it to the vehicle wiring harness.

E. Secure the door latch cable to the door frame so it will not rattle.

F. Make sure the power window switch is connected to the harness, protect it from moisture and secure the harness inside the door frame away from the window travel.

Note: The window switch must be reinstalled. If window switch is not reinstalled the vehicle will register that the door is ajar. Furthermore, the driver will not have the ability to roll the window up or down.

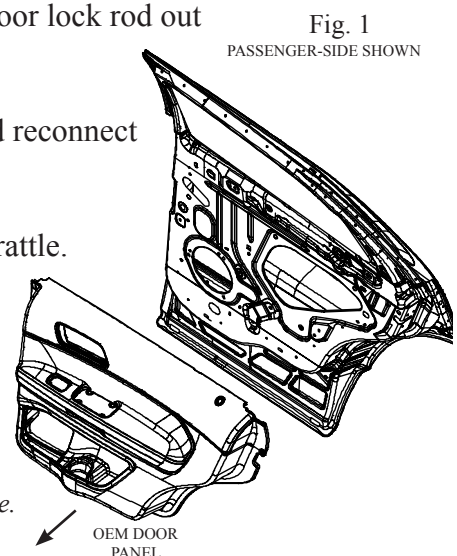
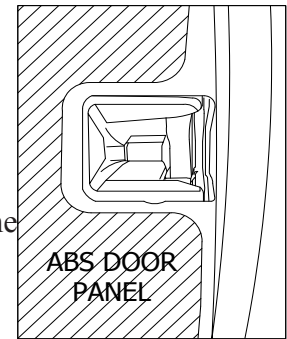

Fig. 1
PASSENGER-SIDE SHOWN

V. ABS Door Panel Installation

- A. Place the window seal back onto the door frame as though the door panel was there.
- B. Next, place the ABS Door Panel against the door and align. Once the panel fits flush around the door latch (see Fig. 2), install one (3X72) screw in to both sides of the door. Ensure that the side of the ABS Door panel closest to the door hinges is flush with the door.
- C. Attach the remainder of the door panel, from top to bottom with the supplied screws (3X72), Type A-self tapping, sometimes it is necessary to drill a 3/32" pilot. (See Fig. 3)

Fig. 2
PASSENGER-SIDE SHOWN



VI. Window Armor Installation

- A. Raise the Window Armor above the ABS door panel. Then lower the Window Armor so that the ABS door panel slides into the Window Armor's lower bracket. Ensure that the retaining flanges on lower bracket fit onto the window seal correctly. Continue to force down until it locks into place.
- B. Center the outside of the metal mounting frame on the door from side to side. While applying pressure down on the Window Armor, mark two horizontal lines on the factory trim that surrounds the window frame. (See Fig. 5)
- C. Next, remove the Window Armor by pulling on the inner tab from the lower bracket and lift. Remove the window trim and cut off the upper section of the factory trim. Now reinstall the trim and Window Armor.
- D. Align the upper bracket of the Window Armor to the upper door frame, before securing.
- E. Install six screws in the upper bracket of the Window Armor. Using the (3X72) #8 x 5/8 self tapping screws. Followed by the remaining two lower screw locations in the lower bracket of the Window Armor. (See Fig. 4)
- F. Lastly, ensure that the window trim is flush to the bottom of the upper Window Armor bracket and install a single screw at the top of each side. (See Fig. 5)

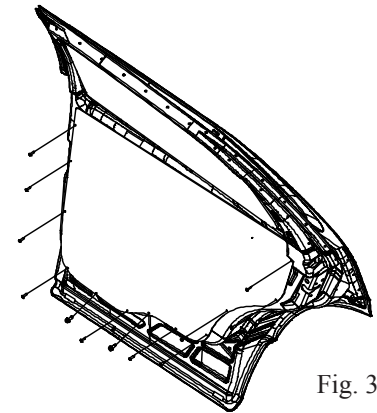
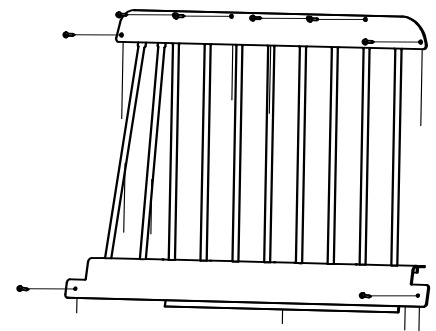

Fig. 3
PASSENGER-SIDE SHOWN

Fig. 4
DRIVER-SIDE SHOWN



VII. Installation Complete

Fig. 4
DRIVER-SIDE SHOWN

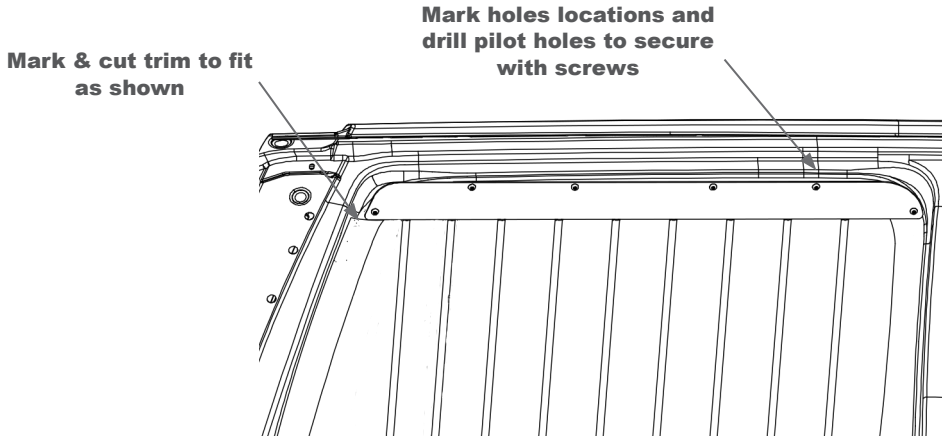

If you have any problems with this installation than call the toll free number (800-480-6680) and ask for technical assistance.

WINDSHIELD			
ITEM	QTY	PART NUMBER	DESCRIPTION
1	1	3005-ALL-P	WINDSH BNS /WB - P/RECOVER
2	1	3005-ALL-D	WINDSH BNS /WB - DRIVER
WINDSHIELD			
ITEM	QTY	PART NUMBER	DESCRIPTION
3	20	3092	8-32 X 5/8 PHIL PAN HD SB
DOOR PANELS			
ITEM	QTY	PART NUMBER	DESCRIPTION
4	1	3005-PS-OLP	/WB DOOR PANEL, BELMONT/CP PS
5	1	3005-PS-OLD	/WB DOOR PANEL, BELMONT/CP DS
DOOR PANELS			
ITEM	QTY	PART NUMBER	DESCRIPTION
6	20	3092	8-32 X 5/8 PHIL PAN HD SB

