

**INSTALLATION GUIDE**  
**SKID PLATE SK56C11**  
**2011 - CURRENT**  
**DODGE CHARGER 3.6L V6**

**Pro-gard™**  
PRODUCTS LLC.

STRONG | RELIABLE | SECURE

**pro-gard.com**  
**800.480.6680**

THESE COMPONENTS ARE REQUIRED  
TO INSTALL THE PRO-GARD SKID PLATE SYSTEM

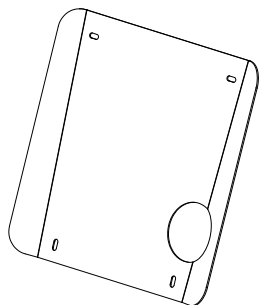

SK56C11 SKID PLATE



HARDWARE KIT

- I. Refer to the diagram on the last page of these instructions to verify all parts were received.
- II. The following tools will be required to complete the installation.
  - A. 3/8" or 1/2" drive ratchet with 10mm and 8mm sockets
- III. Read all instructions carefully before starting the assembly process.

**NOTE:** *Locate any Wiring, Fuel Lines, Brake Lines, and/or Cooling Lines before drilling holes or installing Fasteners.*

IV. Removing OEM Plastic Debris Shield

- A. Remove the four fasteners holding the OEM Debris Shield to the vehicle underbody. (See Fig. 1)
- B. Remove and discard the Shield and hardware as it will not be used in this application.

FIG 1  
UNDER BODY SHOWN

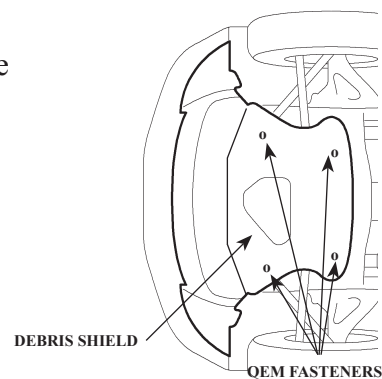

V. Installing the Skid Plate

- A. Orient the Skid Plate (3SK56C11) so that the oil drain slot aligns with the Engine Oil Drain Plug. Using the supplied bolts (3X201) and washers (3X202) attach the Skid Plate to the vehicle utilizing the OEM anchor points from the OEM Debris Shield. (See Fig. 2)
- B. Ensure all fasteners are tight.

FIG 2  
FRONT OF VEHICLE SHOWN

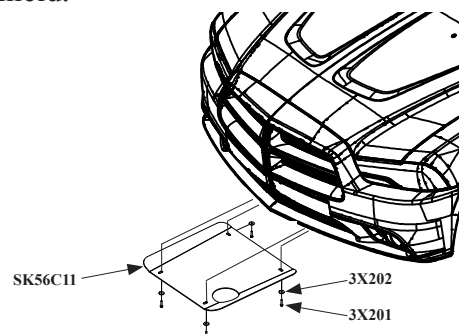

VI. Installation complete.