

**INSTALLATION GUIDE**  
**SKID PLATE 3SK47UINT16**  
**2016 - 2019**  
**FORD INTERCEPTOR UTILITY**

**Pro-gard**<sup>™</sup>  
PRODUCTS LLC.

STRONG | RELIABLE | SECURE

**pro-gard.com**  
**800.480.6680**

THESE COMPONENTS ARE REQUIRED  
TO INSTALL THE PRO-GARD SKID PLATE SYSTEM

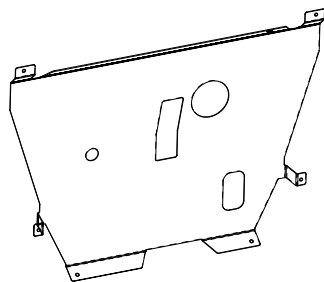

3SK4716 SKID PLATE



HARDWARE KIT

- I. Refer to the parts list at the end of the page to verify all parts were received.
- II. The following tools will be required to complete the installation.
  - A. 3/8" or 1/2" drive ratchet with 14mm socket, and a 14mm open or box end wrench

IV. Installing the Skid Plate

*NOTE: If installing on a Eco-Boost Utility. Remove factory skid plate and factory skid plate mounting bracket.*

A. Remove the 3 (or 5) retainers and remove the underbody air duct (or optional underbody splash shield). (See Fig. 1)

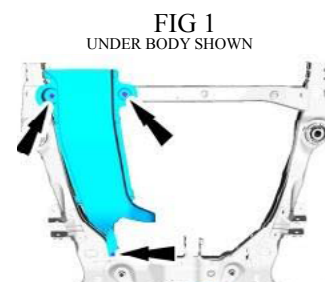

B. Install the 3SK4716A brackets to the rear 2 holes of the skid plate, by using the two 3X131 bolts with four 3X121 washers, and two 3SK4716B inserts found in the hardware kit. Slide the inserts into place over the skid plate into the hole location. Tighten the brackets to the point that they can still rotate slightly.

C. Install the 3SK4715C brackets to the middle 2 holes of the skid plate, by using the two 3X131 bolts with four 3X13 washers, and two 3X120 locknuts found in the hardware kit. Tighten the brackets just to the point that they can still rotate slightly.

D. Hook the mount brackets into the slots on the sub frame and swing the skid plate up into place, maintaining forward pressure while performing the next step.

Mounting Locations

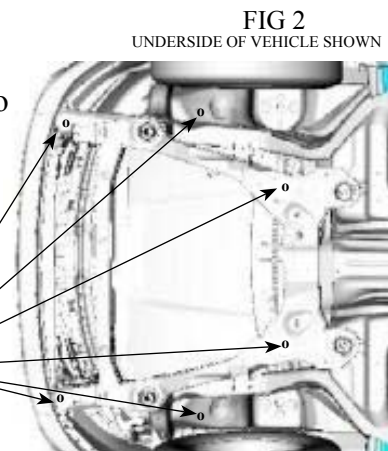

E. Check that the Skid Plate access holes align with the appropriate engine features. The formed edge should tuck up behind the radiator support. Now use the supplied bolts and place two 3X114 in the front 2 holes, two 3X131 into the middle two holes along with the 8 remaining washers (3X13) and 4 nuts (3X120).

F. Attach the Skid Plate to the vehicle utilize the OEM anchor points. (See Fig. 2) Ensure all fasteners are tight (Torque between 35-40 ft lbs). Tighten the fasteners on the 3SK4715A bracket the rest of the way. Then tighten all remaining fasteners.

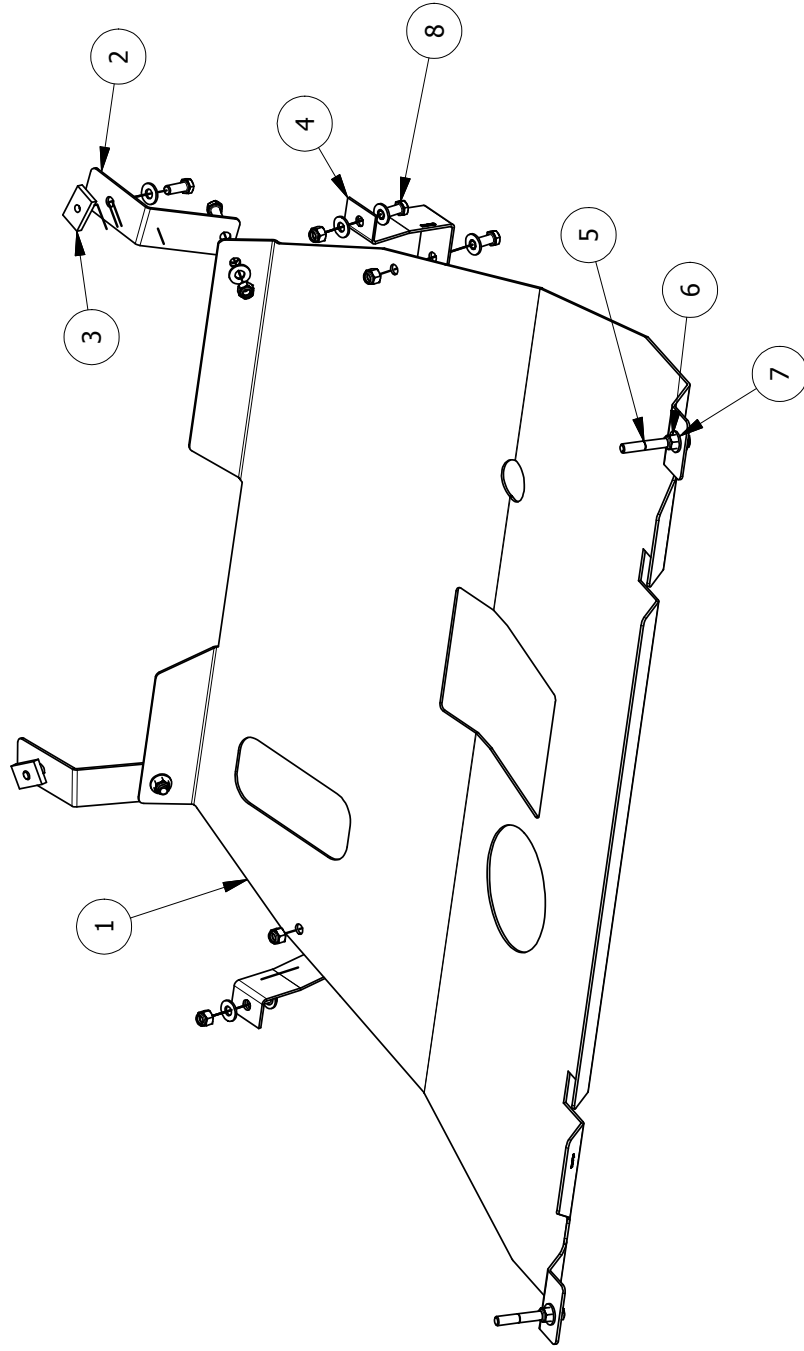

PARTS LIST

ITEM	QTY	PART NUMBER	DESCRIPTION	MATERIAL	FINISH
1	1	3SK4716	SKID PLATE	STEEL, 12 GA HRPO	POWDER COAT BLACK
2	2	3SK4716A	MOUNTING BRACKET	STEEL	POWDER COAT BLACK
3	2	3SK4716B	THREADED INSERT	STEEL	POWDER COAT BLACK
4	2	3SK4716C	HANGER BRACKET	STEEL	POWDER COAT BLACK
5	2	3X114	3/8-16x2.75, HEX HD CAP SCREW, GR 8, YZ	STEEL	YELLOW ZINC
6	8	3X120	3/8-16, Hex Nylon Insert Locknuts, Grade 8, YZ	STEEL	YELLOW ZINC
7	16	3X13	3/8 FLAT WSHR, YZ	STEEL	YELLOW ZINC
8	8	3X131	3/8-16X1, HEX HD CAP SCREW, GR8, YZ	STEEL	YELLOW ZINC