

**INSTALLATION GUIDE**

**SPACE SAVER PARTITION**

**PRPSP81XX16A**

**2016 - 2020 F-150 4- DOOR**

**Pro-gard**<sup>™</sup>  
PRODUCTS LLC.

**STRONG. RELIABLE. SECURE.**

**THESE COMPONENTS ARE REQUIRED  
TO INSTALL THE PARTITION**

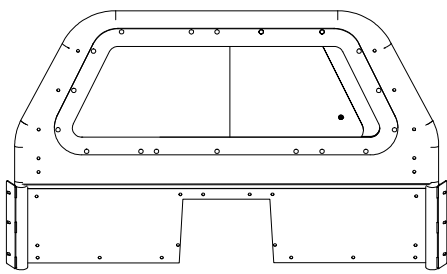

4P57--T15

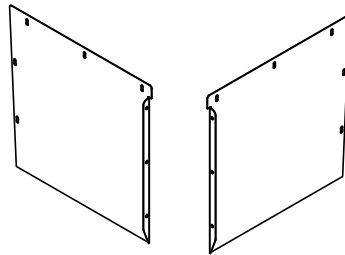

3SP8116-D & P

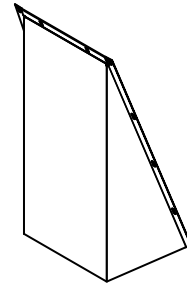

3RP8116

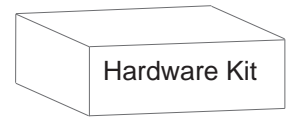

4PK8116



4WK8116FTA

**I. The following tools will be required to complete the installation.**

- A. 7/16" Socket & Ratchet
- B. 7/16" Open ended Wrench
- C. 3/16" Allen Wrench
- D. 3/8" Socket & Ratchet
- E. 3/16 "Drill Bit
- F. 1" Hole Saw & Drill Bit

**II. Read all instructions carefully and refer to pages 5 & 6 to ensure all parts were received.**

**WARNING:** *Locate All wiring, fuel lines, brake lines, coolant lines, or reffridgerant lines before drilling any holes or installing any self-drilling fasteners.*

**III. Preparing the B-Pillar.**

A. Locate and remove the lower part of the b-pillar trim to access the sheet metal body. After the trim is removed put the 3P8116D & 3P8116P b-pillar brackets in location and mark the 4 holes to drill a pilot (with 3/16" drill bit) for the self tapping screws (3X162). The b-pillar bracket is located by matching the bends in the bracket with the bends in the b-pillar sheet metal, and aligning the top of the bracket with the bottom of the upper b-pillar trim. Secure the b-pillar brackets to the driver & passenger sides of the vehicle with the self-tapping screws.

B. Use the supplied b-pillar templates on the last 2 pages to mark the three holes in the lower b-pillar trims and drill out the 1" holes so the standoffs can fit through and re-install the trim.

Align the bracket with the trim here

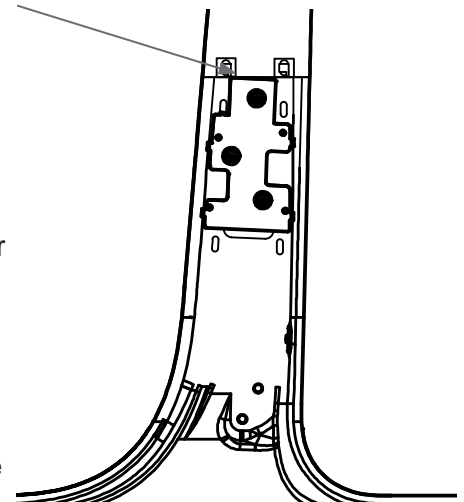

Fig. 1

## IV. Partition Installation.

- A. When b-pillar bracket installation is completed and the trim is reinstalled, then the lower sheet metal side panels (3PK8116-02D & 3PK8116-02P) can be installed.
- B. Use three (3X149) screws to bolt the driver and passenger side panels into place leaving bolts loose until the partition is installed. (See fig. 2)
- C. At this point the partition can be installed into the vehicle. We recommend that two people lift and install the partition in place. Carefully lift the partition with another person thru the second row doors. When the partition is in the second row seat area then lift the bottom of the partition and place it on the front side of the sheet metal panels. Install the three (3X36) bolts and (3x16Z) whiz nuts on the side tabs of the partition to hold it in place. (See fig. 3)
- D. Have one person hold the partition tight to the ceiling of the vehicle while the other person tightens all the loose mounting screws on the panels. Be sure the roll bar fits tight inside the sheet metal panels with no gaps. (See fig. 4)

Install the lower sheet metal panels to b-pillar brackets

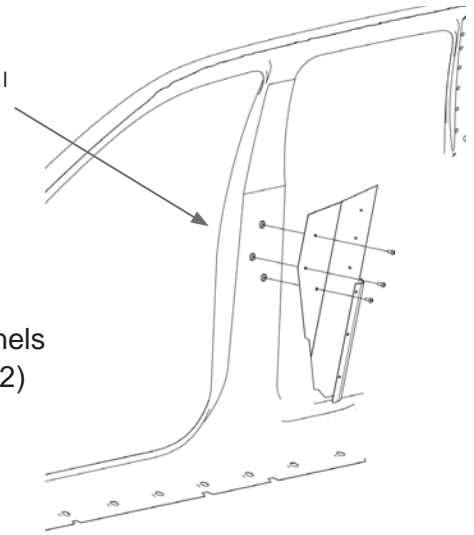
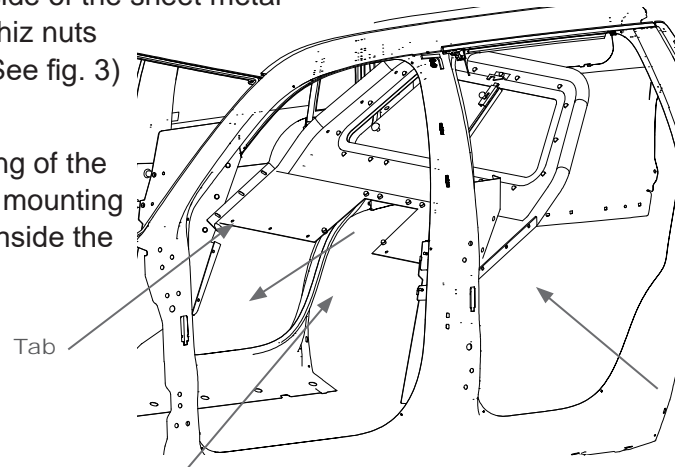

fig. 2



Slide partition to front of side panels

fig. 3

## V. Seat Protector & Recess Panel Installation

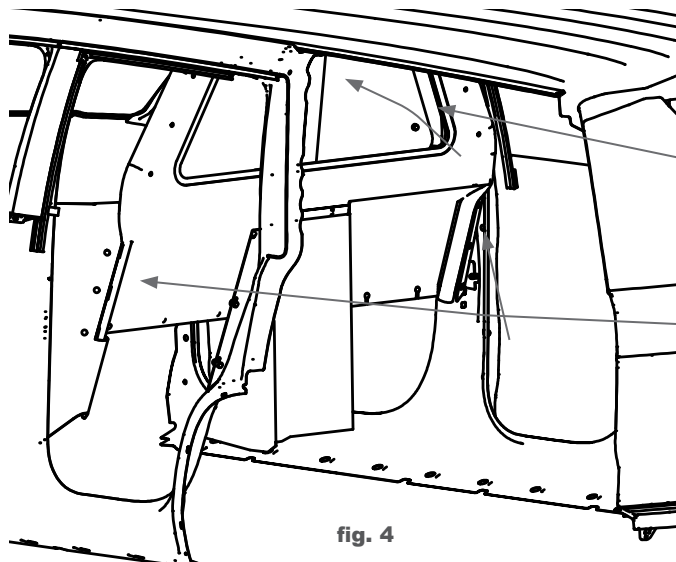

Hold partition tight to ceiling while tightening bolts

Ensure the roll bar and sheet metal are tight in these areas!

fig. 4

- A. Put the recess panel (3RP8116) in place and get two bolts and nuts started at the top of the recess panel and partition. (See diagram on page 5 and Fig. 5)

Place seat protector in location from the front of the vehicle. **Install and start side bolts first. Next** install all other bolts second.

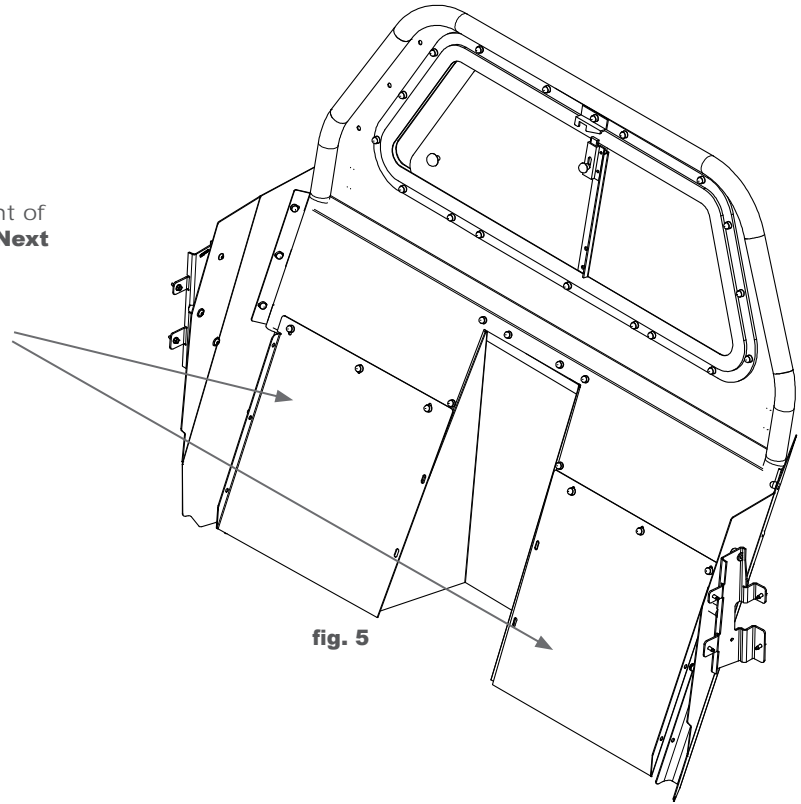

B. To install the bucket seat protectors (3SP8116 - D & P) put both seat protectors on the front side of the partition as shown above. Line up the holes in the side tabs first and put the 3X36 bolts and 3X16Z whiz nuts through the holes and hand tighten. Adjust the seat protectors as needed, then tighten all bolts securely to finish installation. (See Fig. 5)

## **Installation complete!**

**If you have any problems with this installation then call the toll free number (800-480-6680) and ask for technical assistance.**

PARTS LIST			
ITEM	QTY	PART NUMBER	DESCRIPTION
1	1	4P57_T15	2015 TAHOE PARTITION
2	1	3PK8116-02P	PARTITION MOUNTING PLATE, PASSENGER
3	1	3PK8116-02D	PARTITION MOUNTING PLATE, DRIVER
4	2	3SP8116-P	SEAT PROTECTOR, PASSENGER
5	1	3SP8116-D	SEAT PROTECTOR, DRIVER
6	1	3RP8116	RECESS PANEL
7	1	3PK8116D	B-PILLAR BRACKET ASSY. DS
8	1	3PK8116P	B-PILLAR BRACKET ASSY. PS

HARDWARE LIST		
ITEM	QTY	DESCRIPTION
9	30	1/4-20 X 5/8 CARRIAGE BOLT
10	30	1/4-20 WHIZ NUT
11	6	5/16-18 X 3/4 BSHCS. BK
12	8	#14 X 3/4" SELF DRILLING HEX HEAD SCREW
13	30	BLACK PLASTIC CAP

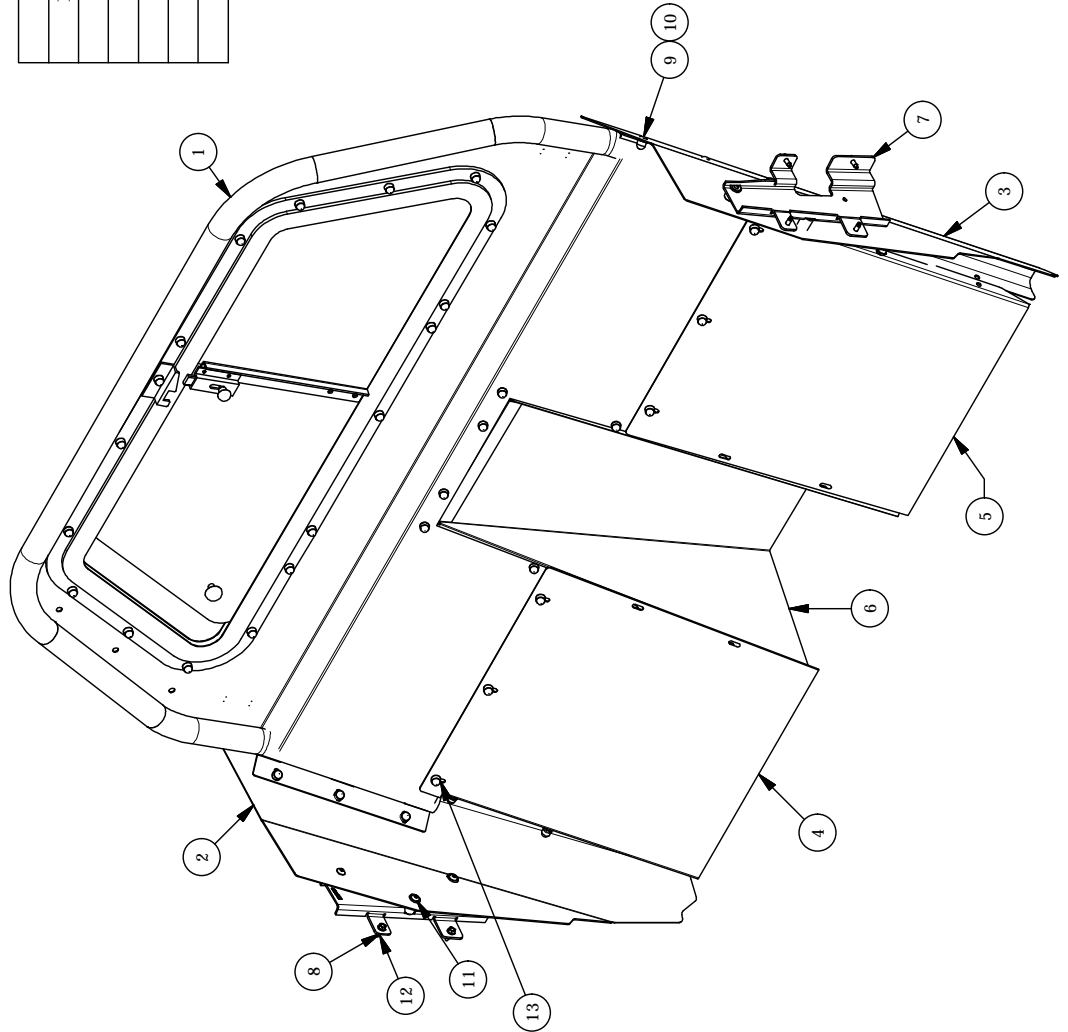

ALIGN CUT OUTS HERE

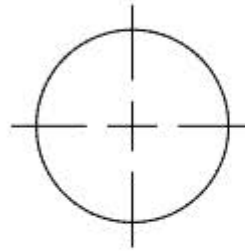

**DIRECTIONS**

1. CUT ALONG DASHED LINES
2. REMOVE THE B-PILLAR TRIM AND PLACE TEMPLATE INSIDE, ALIGNING CUT-OUT AREAS WITH THE CORRESPONDING FEATURE SHOWN
3. CENTER PUNCH 3 HOLE LOCATIONS THRU TEMPLATE AND DRILL/CUT 1" DIA HOLE
4. REINSTALL TRIM PANELS OVER TOP OF THE B-PILLAR BRACKETS

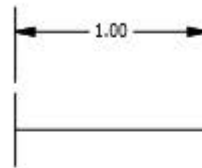
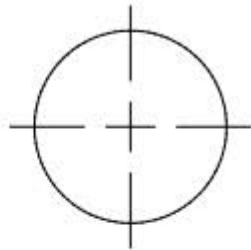

CHECK SCALE  
SELECT NONE FOR PAGE SCALING  
WHEN PRINTING FROM .pdf FILE

2016+ F-150  
B-PILLAR TRIM TEMPLATE  
DRIVER SIDE

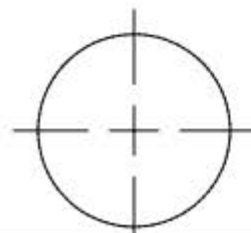

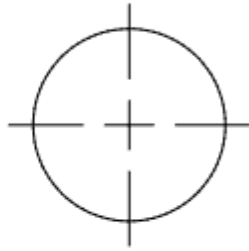

**DIRECTIONS**

1. CUT ALONG DASHED LINES
2. REMOVE THE B-PILLAR TRIM AND PLACE TEMPLATE INSIDE, ALIGNING CUT-OUT AREAS WITH THE CORRESPONDING FEATURE SHOWN
3. CENTER PUNCH 3 HOLE LOCATIONS THRU TEMPLATE AND DRILL/CUT 1" DIA HOLE
4. REINSTALL TRIM PANELS OVER TOP OF THE B-PILLAR BRACKETS

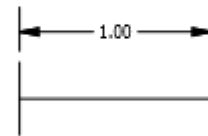
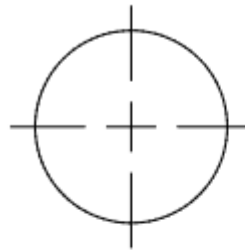

CHECK SCALE  
SELECT NONE FOR PAGE SCALING  
WHEN PRINTING FROM .pdf FILE

2016+ F-150  
B-PILLAR TRIM TEMPLATE  
PASSENGER SIDE

