

INSTALLATION GUIDE

PB57T15HD

PUSH BUMPER

**2015 - CURRENT CHEVROLET
TAHOE/SUBURBAN**

2016 - CURRENT

CHEVROLET SILVERADO

Pro-gard™
PRODUCTS LLC.

STRONG | RELIABLE | SECURE

**pro-gard.com
800.480.6680**

THESE COMPONENTS ARE REQUIRED
TO INSTALL THE PRO-GARD PUSH BUMPER

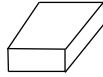

4PBK5715HD
HARDWARE KIT

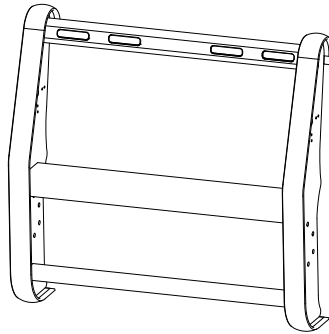

4PBTHD
UNIVERSAL TRUCK PUSH
BUMPER

I. Refer to the diagram on last page to verify all parts were received.

II. The following tools will be required to complete the installation:

| | | |
|--------------|----------------|---------------|
| 9/16" socket | 7mm socket | 3/4" wrench |
| 3/4" socket | 10mm socket | Utility knife |
| 18mm wrench | 3/4" extension | |

III. Read all instructions carefully before starting the assembly process.

NOTE: *Locate all wiring, fuel lines, brake lines, and /or cooling lines before drilling holes or installing any fasteners.*

If installing on a Tahoe/Suburban Proceed to step IV., or step V. for a Silverado.

IV. Tahoe/Suburban: Tow Hook Removal

A. Remove the OEM tow hooks from the vehicle (if so equipped). **(Proceed to step VI.)**

V. Bumper Assembly Removal (Silverado)

A. Under the hood, pry the multiple plastic retainers from plastic radiator top cover and remove.

B. Remove the 10mm bolts that attach the top of the grille located where the plastic radiator top cover was just removed. Underneath the top of the grille, where the bolts were removed, are several more plastic retainers that need to be removed.

C. Carefully remove the grille from the vehicle, which is held on only by clips at this point.

- D. Remove the bumper valence by locating the 7mm bolts attaching it to the underside of the bumper and removing them. An extension may be needed to remove some of the bolts through the opening made by removing the grille.
- E. Remove/loosen the bumper assembly as required to remove tow hook fasteners.
- F. Remove the OEM tow hooks from the vehicle (if so equipped), and re-fasten the bumper assembly.

VI. Push Bumper Bracket Installation

- A. If vehicle is not equipped with OEM tow hooks, the trim will need to be modified as shown in figure 1. 1.5 inches of trim should be removed from the center of the trim outward on both sides. **If installing on a Silverado, Suburban or Tahoe the area around the tow hook slot will need to be trimmed to fit the bracket accordingly.**
- B. Repeat trim modification for opposite side of vehicle.
- C. Insert the lower mounting bracket (3PBK5716-01D) into the driver's side tow hook opening. Secure from underneath the vehicle using the provided 3X131 bolt and 3X224 washer. Secure both sides of the bracket to the frame rail using the 3X131 bolts and 3X121 washers.
- D. Repeat step E for the opposite side of the vehicle using 3PBK5716-01P.

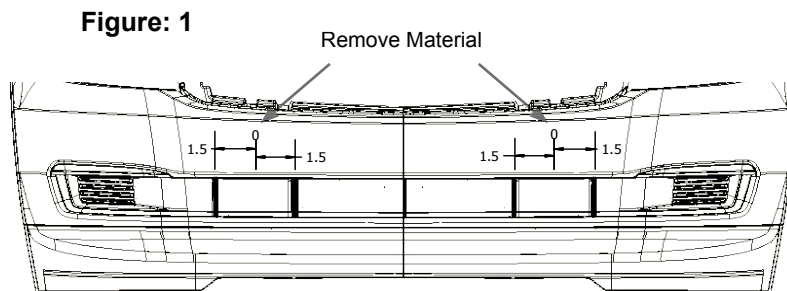

VII. Push Bumper Installation

- A. Carefully align the four holes located on each side of the lower portion of the push bumper (4PBTHD) with both mounting brackets (3PBK5715-04P & D). Secure the push bumper to the brackets using the provided 3X174 bolts, 3X175 lock washers, and 3X176 nuts. (Refer to page 4)
- B. Tighten all fasteners and ensure push bumper is securely mounted to the vehicle.

VIII. Installation Complete

| PARTS LIST | | | |
|------------|-----|--------------|--|
| ITEM | QTY | PART NUMBER | DESCRIPTION |
| 1 | 1 | 3PBK5716-01P | LOWER MOUNTING BRACKETS |
| 2 | 1 | 3PBK5716-01D | LOWER MOUNTING BRACKETS |
| 3 | 1 | XXXXX | TRUCK PUSH BUMPER (PART NUMBER VARIES) |

| HARDWARE LIST | | | |
|---------------|-----|-------------|-----------------------------------|
| ITEM | QTY | PART NUMBER | DESCRIPTION |
| 4 | 8 | 3X174 | 1/2-13 X 1" HHCS. GR8, BLK Zn/C |
| 5 | 8 | 3X175 | 1/2" WSHR SPLIT LOCK, BLK Zn/C |
| 6 | 8 | 3X176 | 1/2-13 NUT, GR8, BLK Zn/C |
| 7 | 4 | 3X121 | 3/8 FLAT WSHR, YZ |
| 8 | 2 | 3X224 | 3/8 X 1 1/2 WASHER |
| 9 | 6 | 3X131 | 3/8-16 X 1.00" HEX HD YELLOW ZINC |

