

INSTALLATION GUIDE

PB47UINT16HD

PUSH BUMPER

2016 - 2019

Pro-gard[™]
PRODUCTS LLC.

STRONG | RELIABLE | SECURE

pro-gard.com
800.480.6680

THESE COMPONENTS ARE REQUIRED
TO INSTALL THE PRO-GARD PUSH BUMPER

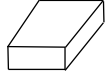

4PB4716 HD
HARDWARE KIT

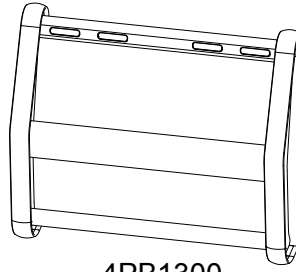

4PB1300
UNIVERSAL SUV PUSH BUMPER

I. Refer to the diagram above and on last page to verify all parts were received.

II. The following tools will be required to complete the installation:

- | | | |
|---------------------------|--------------------------|-------------------------|
| 1. 7/16" Socket W/ driver | 2. 7/16" Open end wrench | 3. 13mm Socket |
| 4. 13mm Open end wrench | 5. 3/4" Socket | 6. 3/4" Open end wrench |
| 7. 10mm Socket | 8. 5.5mm Socket | 9. 8mm Socket |

III. Read all instructions carefully before starting the assembly process.

NOTE: *Locate all wiring, fuel lines, brake lines, and /or cooling lines before drilling holes or installing any fasteners.*

IV. Front Fascia Removal

- A. Using a 10mm Socket remove the trim cover located under the hood of the vehicle
- B. Remove the 5.5mm bolts located inside both wheel wells.
- C. Locate and remove the 8mm bolts located on the underside of the vehicle.
- D. Carefully remove the fascia from the vehicle, remove/disconnect any wiring.

V. Push Bumper Bracket Installation

NOTE: It may be necessary to remove the front impact member from the vehicle to install the mounting brackets.

- A. Place bracket 3PBK4714-06 behind the impact member aligning the slot with the hole located on the drivers side of the impact member. See figure 1&2.

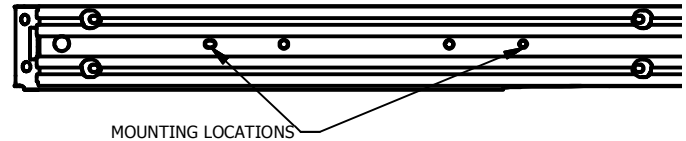

Figure 1.

- B. Align the mounting holes of 3PBK4716-02 with 3PBK4714-06 and insert the provided 1/4-20 bolts into the top mounting holes leaving both loose.

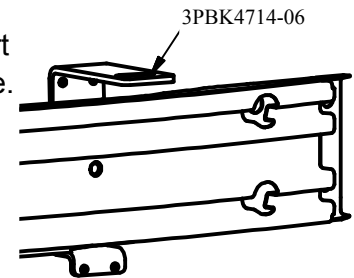

Figure 2.

- C. Insert 3X155 with 3X12 into the hole located in 3PBK4716-02 secure to the back of 3PBK4716-03 with the provided hex nut (3X192) Leave assembly loose.

- D. Secure the lower mounting holes with the provided 1/4-20 bolts and 1/4-20 whiz nuts. (3X39 & 3X16SZ)

- E. Tighten all bolts and repeat process for passenger side of vehicle. Using bracket 3PBK4716-08

- F. Cut and remove lower grille trim from both ends so the lower mounting brackets are able to protrude through. See figure 3.

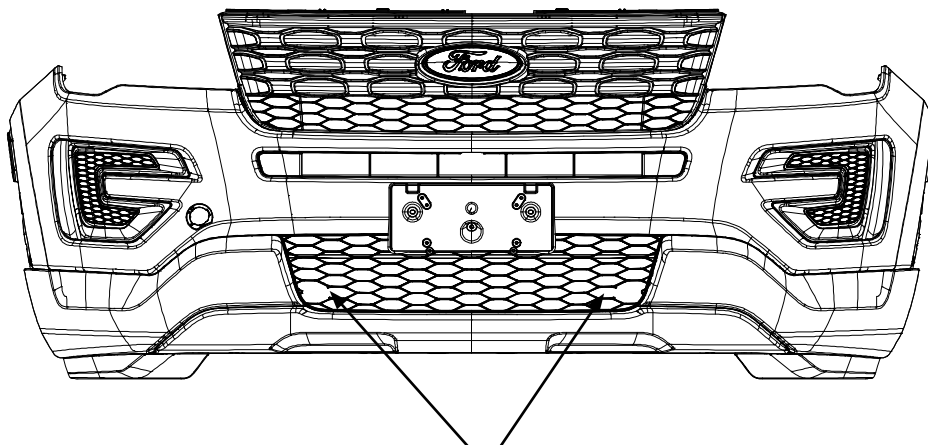

Figure 3.

Cutout trim for brackets

- G. Re-Install the front fascia to the front of the vehicle ensuring that the upper and lower mounting points protrude from the vehicle.

VI. Push Bumper Installation

A. Place bracket 3PBK4714-04 on top of 3PBK4716-08 align the stud with the slot in 3PBK4716-03 and secure using the provided lock washer and nut. Leave assembly loose for adjustment. Repeat process for opposite side of vehicle.

B. Align bracket 3PBK4714-06 on top of 3PBK4716-02 and secure using the provided 1/2-13 bolts, lockwashers, and nuts. Repeat process for the opposite side of the vehicle.

C. Lift the universal push bumper (4PB1300) into place aligning the two lower holes of the push bumper with the holes located in brackets 3PBK4714-05/06. Secure the brackets to the push bumper with the provided 1/2-13 bolts, lock washers, and nuts. See figure 4.

D. Align both 3PBK4714-05/06 on bottom of 3PBK4716-08 and secure using the provided 1/2-13 bolts, lockwashers, and nuts. Repeat process for the opposite side of the vehicle.

E. Ensure that all fasteners are tight and that push bumper is properly secured.

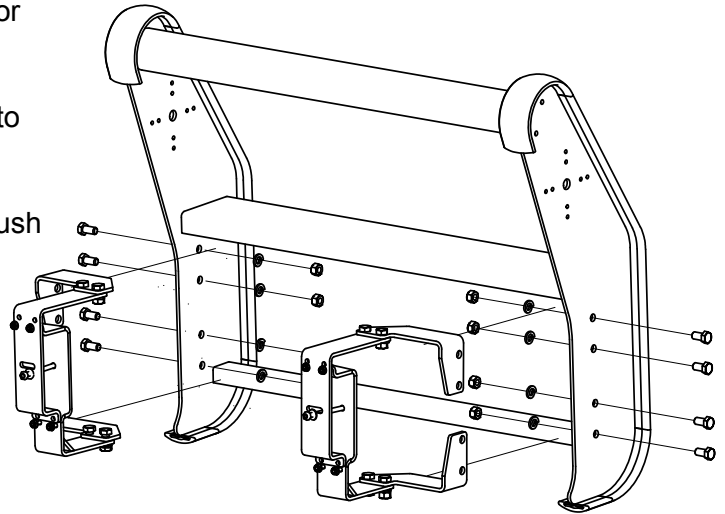

Figure 4.

VII. Installation Complete

2016 SUV BOM

PARTS LIST			
ITEM	QTY	PART NUMBER	DESCRIPTION
1	2	3PBK4714-05	LOWER MOUNTING BRACKET
2	2	3PBK4714-06	LOWER MOUNTING BRACKET #2
3	1	3PBK4716-01	SUPPORT BEAM BRACKET #1
4	1	3PBK4716-02	SUPPORT BEAM BRACKET #2
5	1	4PBSHD	SUV PUSH BUMPER
6	2	3PBK4716-08	IMPACT BEAM BRACKET

HARDWARE LIST			
ITEM	QTY	PART NUMBER	DESCRIPTION
7	16	3X174	1/2-13 X 1" HHCS, GR8, BLK Zn/C
8	2	3X155	M8-1.25X100, HEX HD CAP SCREW 8.8, BLACK
9	2	3X192	M8 X 1.25 HEX NUT, ZINC
10	2	3X12	1/4 FLAT WASHER, BLACK
11	8	3X122	1/4-20 X 1" HHMS, Zn
12	4	3X16SZ	1/4-20 WHIZ NUT
13	16	3X175	1/2" WSHR SPLIT LOCK, BLK Zn/C
14	16	3X176	1/2-13 NUT, GR8, BLK Zn/C
15	2	3X1033	Wshr Split Lock, Zn/C

