

INSTALLATION GUIDE

PB36INT13HD

PUSH BUMPER

HARDWARE KIT

2013 - CURRENT CAR

Pro-gard[™]
PRODUCTS LLC.

STRONG | RELIABLE | SECURE

pro-gard.com
800.480.6680

THESE COMPONENTS ARE REQUIRED
TO ASSEMBLE THE PRO-GARD PUSH BUMPER HARDWARE KIT

I. Refer to the diagram on the last page of these instructions to verify all parts were received.

You will need the following tools:

- | | |
|--------------------------------|--------------------------|
| a. Ratchet with 3/4" socket | b. 10mm socket |
| c. 3/4" Open or box end wrench | d. Torque Wrench |
| e. 5.5mm and 7mm Nut driver | e. Optional 6" extension |

II. Please be sure to read all instructions before installation. All bracket bolts must be torqued down prior to re-installation of fascia. Remaining bolts must not be torqued down until all parts have been installed.

1. Remove the vehicle's front fascia and plastic crush bumper to expose the metal impact beam.
2. Remove 3 8mm bolts holding the transmission oil cooler to the bottom of the impact beam and let it hang down by its mounting tab and cooling lines.
3. Install the passenger side front (3PB361304) and rear (3PB361314) mounting brackets around the impact beam as shown in Fig. 1. The front mount bracket (3PB361304) has a locating pin that should line up with the outer edge of the locating holes seen in Fig. 1 below.

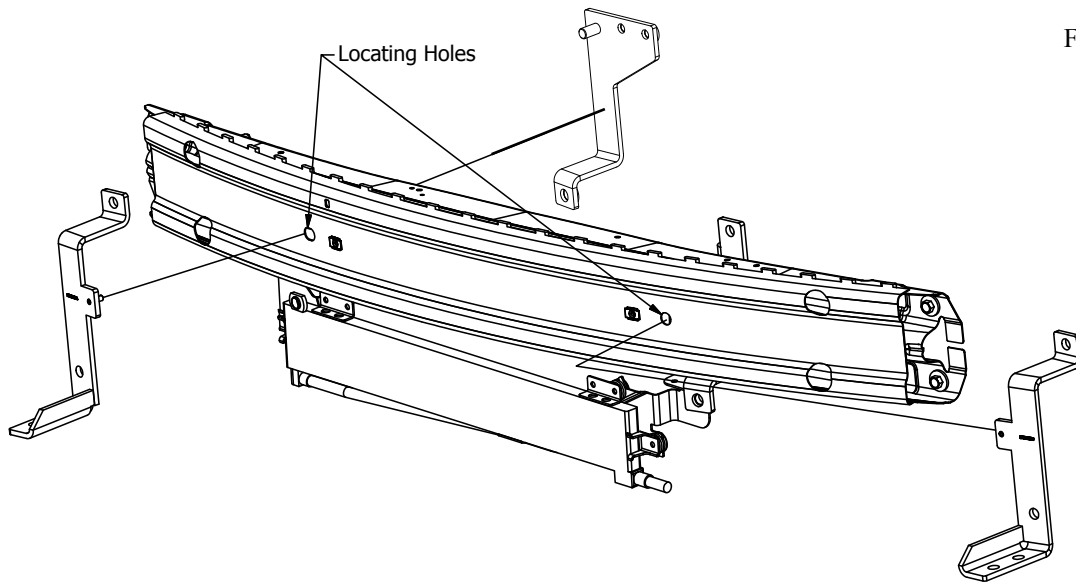
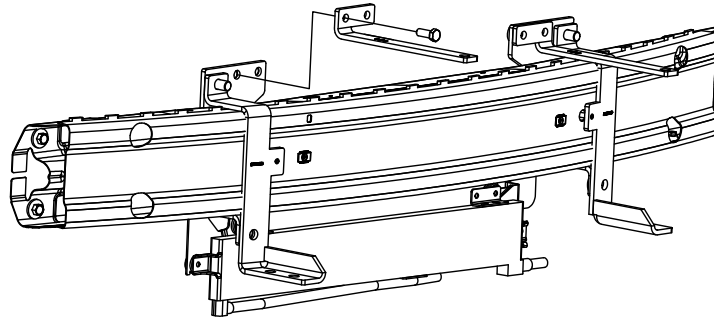

FIG. 1

4. Once the brackets have been properly located, install one 3X175 lock washer and one 3X176 nut on the top stud. Install one 3X174 bolt with a 3X175 lock washer through the lower hole.
5. Repeat steps 3-4 for the driver side. Torque the bracket bolts to 80 ft lbs. Re-secure the transmission oil cooler.

- Install the Upper extension brackets (3PB361315 & 16) as seen in Fig. 2 below. Insert two 3X193 bolts with two 3X228 lock washers (per side) into the brackets and torque the bolts to 35 ft lbs. Be sure there is not interference with the Transmission Oil cooler lines. If there is correct as necessary.

FIG. 2



- Trim the impact beam crush cover at the cross-hatched areas shown below in Fig. 3 to allow clearance for the brackets when reinstalling the front fascia.

FIG. 3

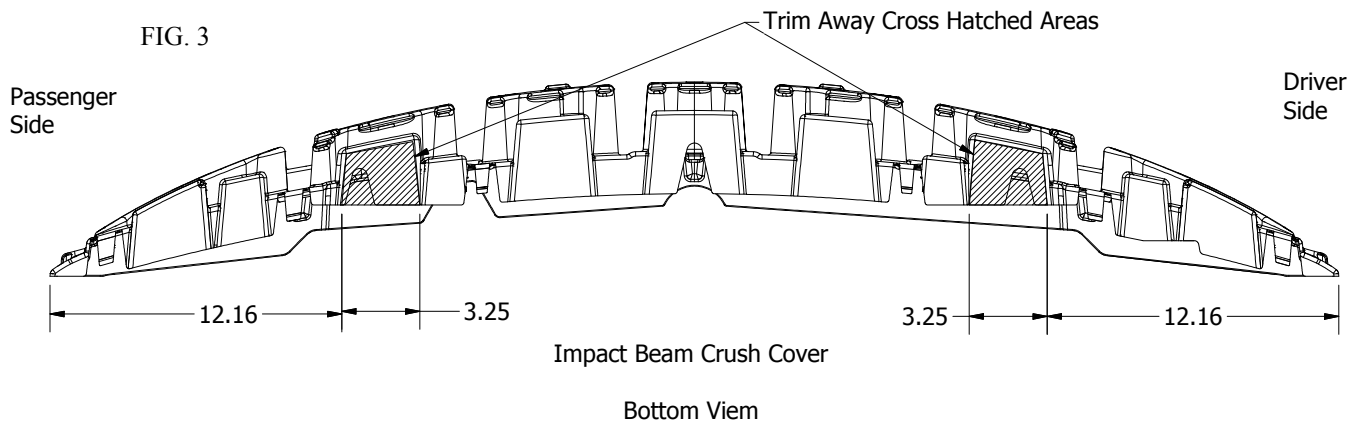

- Replace the impact beam crush cover back onto the rear of the fascia. Re-install the front fascia to the front of the vehicle. See Fig. 4

FIG. 4

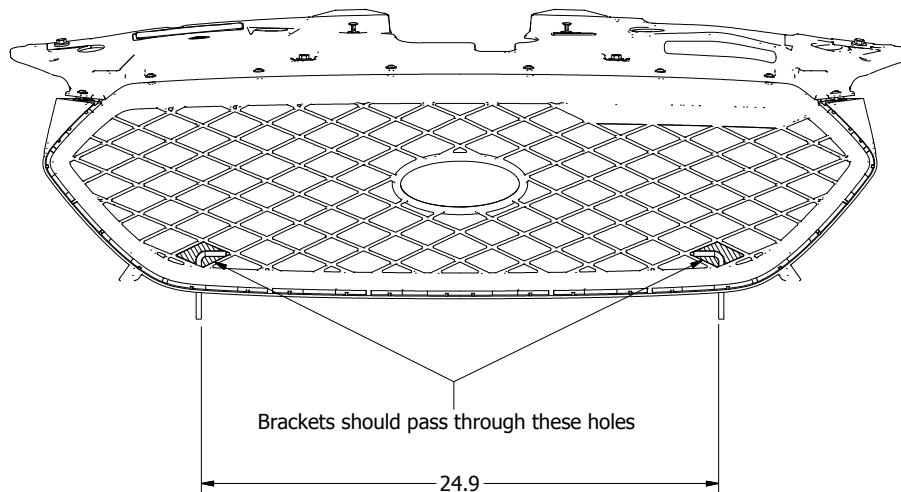

8. Install the lower brackets (3PB361307&08) as shown in Fig. 5 below. Install two 3X174 bolts and two 3X175 lock washers per bracket.

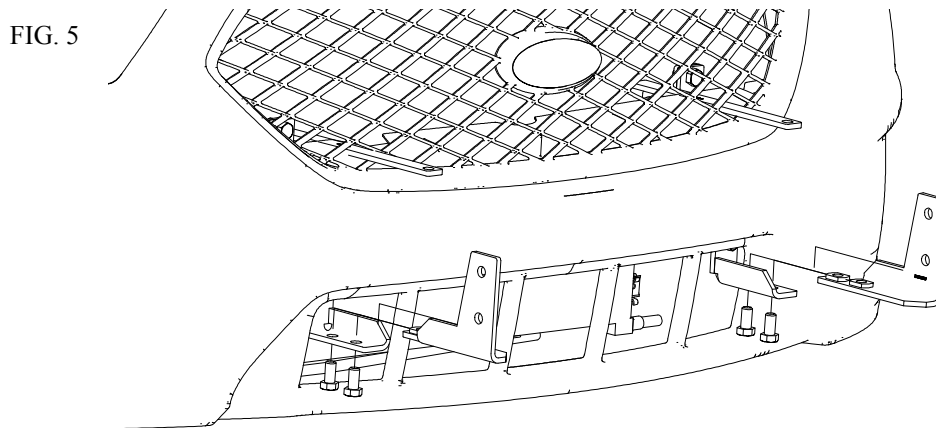

9. Follow assembly instructions included with push bumper 4PBS1100 and assemble the push bumper.
10. Install the push bumper to the vehicle, using 6 ea. of 3X174 bolts, 3X175 lock washers, and 3X176 nuts. See Fig. 6
11. Check overall fit and finish of Push Bumper for level and symmetrical appearance. Torque all remaining 3X174 bolts to 80 ft lbs. Check that all other fasteners are secure.
12. Installation of push bumper is now complete

UNIVERSAL FRONT PUSH BUMPER
ASSEMBLED SEPARATE

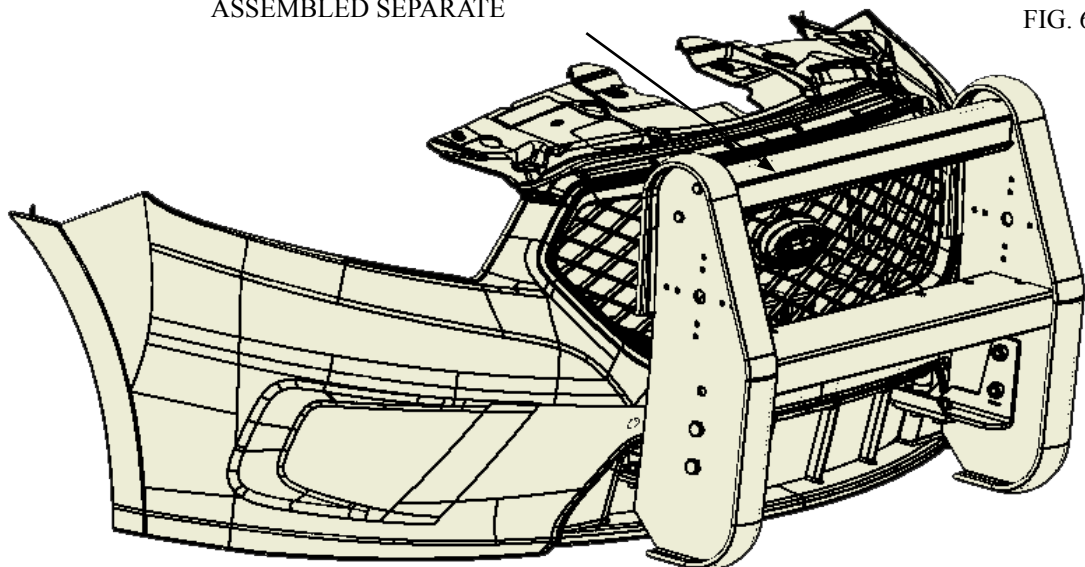

PARTS LIST			
ITEM	QTY	PART NUMBER	DESCRIPTION
1	1	3PB361313	I.B. REAR CLAMP BRACKET, DRIVER
2	1	3PB361314	I.B. REAR CLAMP BRACKET, PASSENGER
3	1	3PB361303	I.B. FRONT CLAMP BRACKET, DRIVER
4	1	3PB361304	I.B. FRONT CLAMP BRACKET, PASSENGER
5	1	3PB361307	LOWER OUTER EXTENSION BRACKET, DRIVER
6	1	3PB361316	UPPER EXTENSION BRACKET, PASSENGER
7	1	3PB361308	LOWER OUTER EXTENSION BRACKET,PASSENGER
8	1	3PB361315	UPPER EXTENSION BRACKET, DRIVER
9	1	XXXXX	CAR PUSH BUMPER (PART NUMBER VARIES)

HARDWARE LIST			
ITEM	QTY	PART NUMBER	DESCRIPTION
10	12	3X174	1/2-13 X 1" HHCS, GR8, BLK ZN/C
11	8	3X176	1/2-13 NUT, GR8, BLK ZN/C
12	18	3X175	1/2" WSHR SPLIT LOCK, BLK ZN/C
13	4	3X193	3/8-16 X 1" HHCS, GR8, BLK ZN/C
14	4	3X228	3/8 SPLIT LOCK WASHER BLK, ZN

