

INSTALLATION GUIDE

2009 - 2017

STANDARD PARTITION

P5800 SERIES

FORD EXPEDITION

STANDARD AND EL

Pro-gard[™]
PRODUCTS LLC.

STRONG | RELIABLE | SECURE

pro-gard.com
800.480.6680

THESE COMPONENTS ARE REQUIRED
TO INSTALL THE PRO-GARD PARTITION SYSTEM

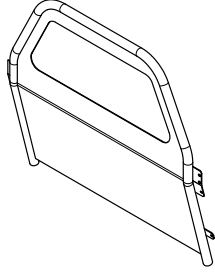

P5800 SERIES
STANDARD PARTITION

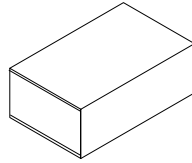

4K5809A
HARDWARE KIT

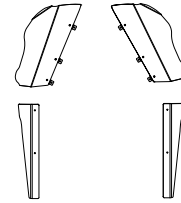

W5809A
WING KIT

- I. Refer to the diagram on the last page of these instructions to verify all parts were received.
- II. The following tools will be required to complete the installation.
 - A. 1/4" drive ratchet with 7/16" socket
 - B. 3/8" drive ratchet with 15mm socket
- III. Read all instructions carefully before starting the assembly process.
- IV. Partition Installation

A. Remove the outside OEM seat mounting bolts at the rear of both front seats so the (3K5803P & D) Lower Mount assemblies can slide under the seat frame. Align holes and reinstall the OEM bolts/nuts. Leaving loose to allow adjustment later.

B. With the help of another person, place the partition in the rear seat of the vehicle with the window latch side facing up. Lift the Partition up and over the Lower Mounts so the partition rests on the tabs and the two holes at each lower corner align with the slots and secure with 3X36 (5/8") carriage bolts and 3X16Z whiz nuts. Although a little shaky the partition will support itself. Roughly center the partition in the vehicle.

C. Install the B-pillar Brackets by placing them through the rear doors between the seat belts. Swing the front flange out so that it hooks around the front of the b-pillar and engages the rubber door seal strip. Make sure the seat belts are not pinched and run freely. Align the two slots at the rear of the bracket with two holes in the partition

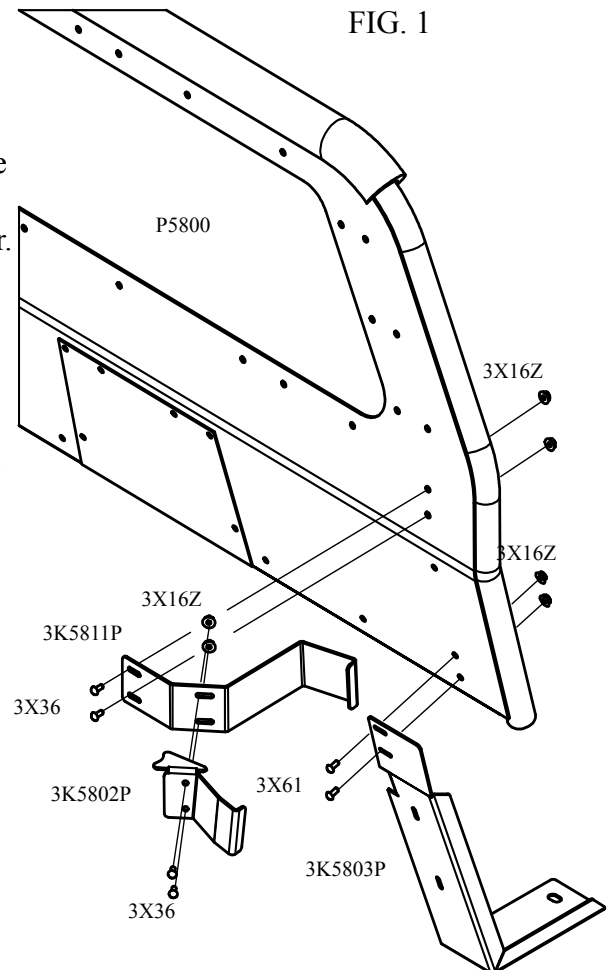

and loosely fasten with two 3X36 (5/8") carriage bolts and 3X16Z whiz nuts. (See fig. 1)

- D. Center the partition by measuring at the b-pillar. Tighten the OEM seat mounting bolts.
- E. Locate the 3P5801P & D B-pillar Clamps against the outside of each B-pillar Bracket so they engage the rubber door seal strip. Attach using 3X61 (3/4") carriage bolts and 3X16Z whiz nuts. Slide the bolts forward in the slots to yield a good clamping action and tighten. (See fig. 1)
- F. Tighten the bolts at the rear of the B-pillar Brackets to secure the partition.
- G. The Filler Wings and their mounting hardware are packed in separate box marked W8109A Wing Kit.

- 1. Attach all six 3P928 Wing Mounting Brackets to the 4W58A series Upper Wings by placing the long leg of the bracket against the inside surface of the wing so the bracket wraps around the edge of the wing. Start the 3X92 (1/2") bolts from the opposite side of the wing and out through the bracket so the 3X16Z nut will tighten against the bracket. (See fig. 2)
- 2. When complete, mount the assemblies to the front side of the partition with the remaining 3X92 bolts and 3X16Z nuts. Be sure the wing is free to flex inward toward the center of the vehicle. (See fig. 2)
- 3. Install the 4W58B Lower Wings on both sides of the vehicle using two 3X36 (5/8") carriage bolts and 3X16Z whiz nuts to secure each. (See fig. 2)

H. Check the overall installation for fit and function of all components. Be sure all fasteners are tight.

I. Installation is complete.

FIG. 2

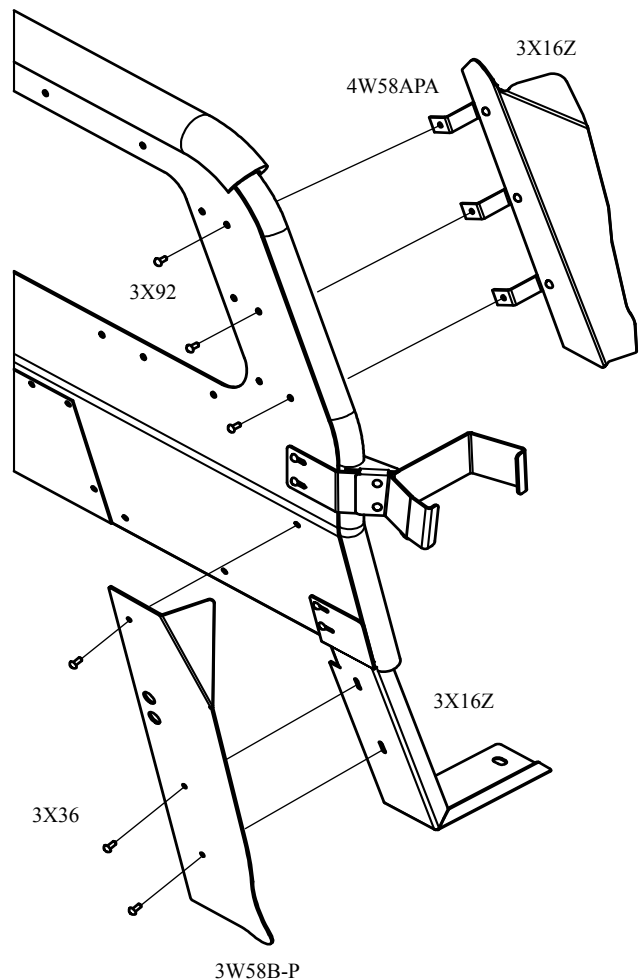

FIG. 3

