

INSTALLATION GUIDE

P1000 PRO-CELL

2016 -2020

Ford F-150

Pro-gard[™]
PRODUCTS LLC.

STRONG | RELIABLE | SECURE

pro-gard.com
800.480.6680

THESE COMPONENTS ARE REQUIRED
TO INSTALL THE PARTITION

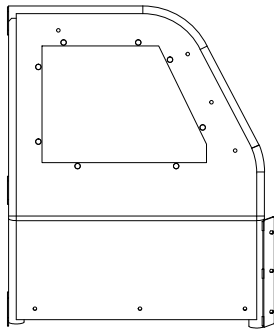

4P1000F150
1/2 Cage Partition

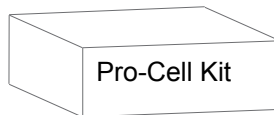

4PK100FT16A

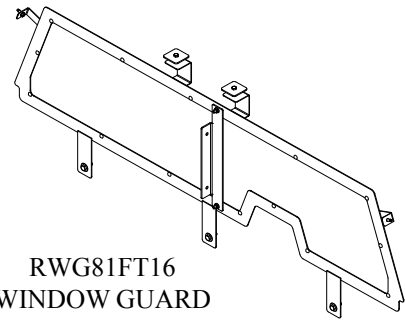

RWG81FT16
WINDOW GUARD

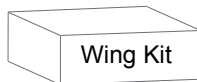

4WK8116FTA-P

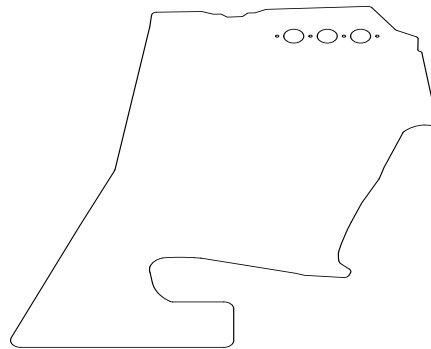

3P8116-WG

I. The following tools will be required to complete the installation.

- A. 7/16" Socket & Ratchet
- B. 7/16" Open ended Wrench
- C. 3/16" Allen Wrench
- D. 3/8" Socket & Ratchet
- E. 3/16" Drill Bit
- F. 1" Hole Saw & Drill Bit
- G. 5/16" Drill Bit

II. Read all instructions carefully and refer to pages 5 to ensure all parts were received.

WARNING: *Locate All wiring, fuel lines, brake lines, coolant lines, or reffridgerant lines before drilling any holes or installing any self-drilling fasteners.*

IV. Preparing the B-Pillar.

- A. Locate and remove the lower part of the b-pillar trim to access the sheet metal body. After the trim is removed put the 3P8116D & 3P8116P b-pillar brackets in location and mark the 4 holes to drill a pilot (with 3/16" drill bit) for the self tapping screws (3X162). The b-pillar bracket is located by matching the bends in the bracket with the bends in the b-pillar sheet metal, and aligning the top of the bracket with the bottom of the upper b-pillar trim. Secure the b-pillar brackets to the driver & passenger sides of the vehicle with the self-tapping screws.

Align the bracket with the trim here

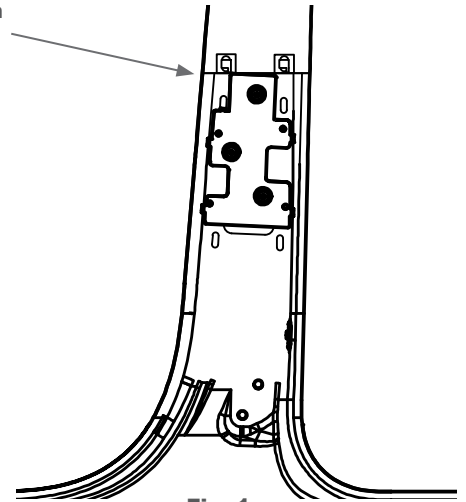

- B. Use the supplied b-pillar templates on the last 2 pages to mark the three holes in the lower b-pillar trims and drill out the 1" holes so the standoffs can fit through and re-install the trim.

V. Mounting Brackets.

- A. When b-pillar bracket installation is completed and the trim is re-installed, then the lower sheet metal side panel (3PK8116-02P) can be installed.
- B. Use three (3X149) screws to bolt the passenger side panel into place leaving bolts loose until the partition is installed. (See fig. 2)

Install the lower sheet metal panels to b-pillar brackets

Must use front holes with Pro-Cell unit

Fig. 2

- C. Loosen the back two OEM bolts of the center console, then push and lift on backside of the console to slide the (3PK8116-14) center support bracket underneath the center console aligning the slots with the OEM bolts before tighten back in place.
- D. Attach the Pro-Cell mounting bracket to the center support with (3X36) screw and (3X16Z) whiz nuts. (See fig. 4 On the Next Page)

VI. Half Cage Installation (With Window Guard)

- A. Install the (3RWG8116) rear window guard by carefully pulling back the head liner by the back window. Then, with the assistance of someone else remove the rear brake light on the outside of the cab. Once removed, there will be two holes one on the left and right-side that is not being used. Align the (3RWG8116-05) hanger plate's hole with the brakes lights holes, then insert the (3X122) bolt through the corresponding holes. Thread the bolt into the weldnut of the upper bracket. (See Fig. 4)
- B. Attach the remaining tabs of the (3RWG8116) to vehicle using the 3X162 self-tapping screws for the side tabs, and the three bottom tabs mount using OEM bolts and hole locations behind the rear seat.
- C. Slide the (3PK8116-10) lower rear bracket through the middle of the seat, lining it's tab up with the other bracket's tabs above it. Then, mount the bracket using the OEM seat stud and bolt.
- D. Place the (3P5715) half cage partition in the vehicle and bolt (3X36) screws and (3X16Z) whiz nuts to b-pillar sheet metal panel on the passenger side and the center mounting bracket behind the console area. Make sure to lift the partition tight to ceiling while securing bolts.

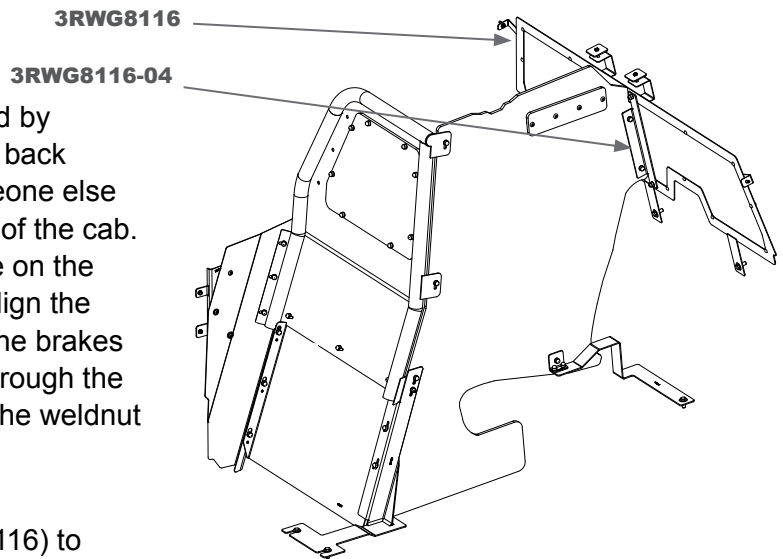

Fig. 5

VII. Divider Installation

- A. Attach (3P8010) vent plate to the 3P8116-WG divider, using the supplied spacers, bolts, and nuts.
- B. Insert the (3P8116-WG) divider through the passenger side door and place in position. Examine the alignment of the profile and adjust to fit. Hold the divider securely with no movement occurring while marking hole locations at the bracket mounting points. Drill 5/16" thru holes and insert (3X82) screws and (3X16Z) whiz nuts. Tighten all divider bolts to secure in position.

VIII. Seat Protector

- IX. Attach (3SP8116-01) seat protect from the backside of the partition. Align partition and center bracket holes and bolt together with (3X36) and (3X61) screws and (3X16Z) whiz nuts. Cover nuts with (3X145) black plastic nuts.

Installation complete!

If you have any problems with this installation then call the toll free number (800-480-6680) and ask for technical assistance.

P1000 Pro-Cell With Window Guard

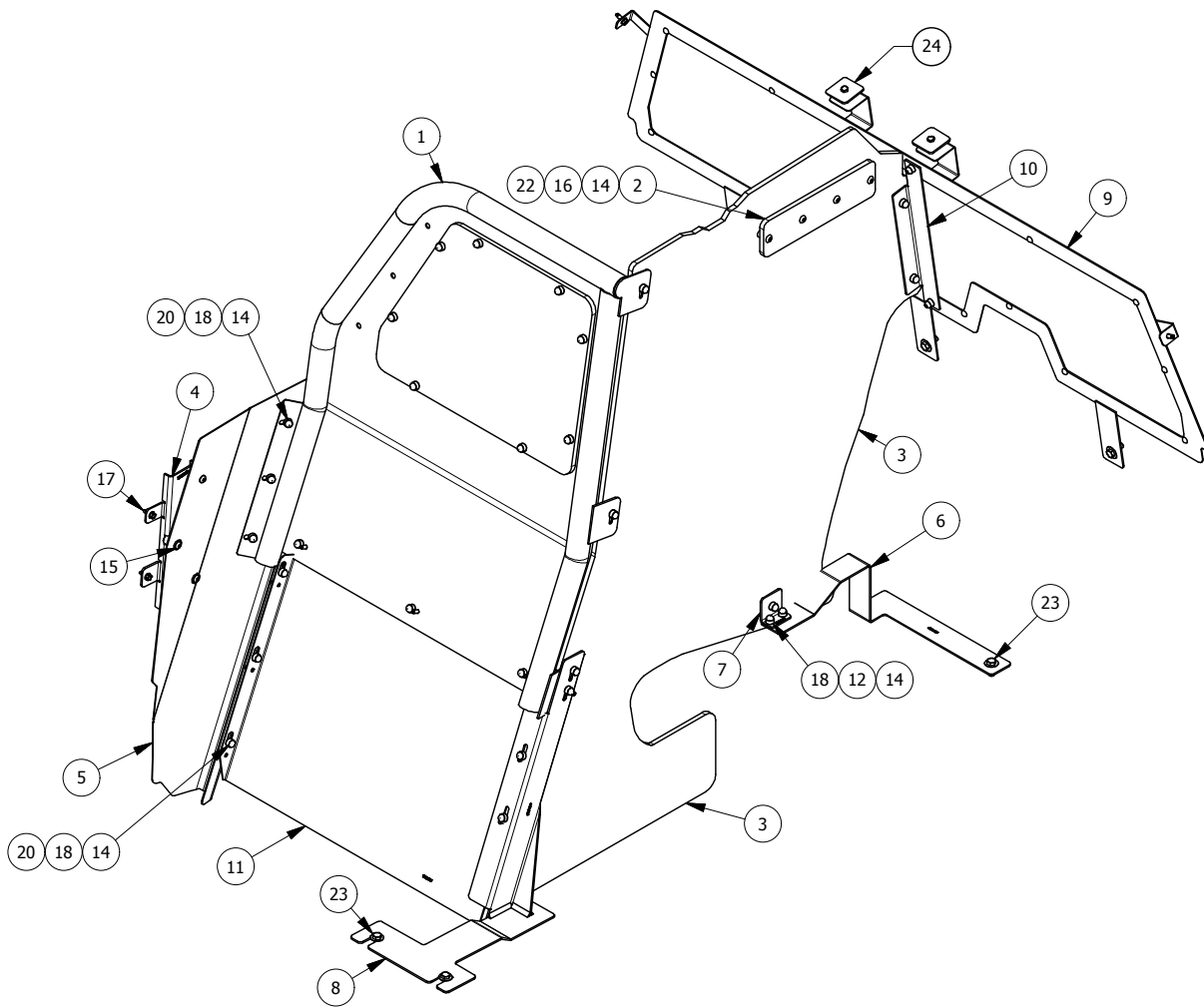

PARTS LIST			
ITEM	QTY	PART NUMBER	DESCRIPTION
1	1	3P5715	PARTITION PRO-CELL TAH 15
2	1	3P8010	DIVIDER VENT PLATE
3	1	3P8116-WG	PRO-CELL DIVIDER, WINDOW GUARD
4	1	3P8116P	B-PILLAR BRACKET ASSY, PS
5	1	3PK8116-02P	PARTITION MOUNTING PLATE, PASSENGER
6	1	3PK8116-10	LOWER REAR DIVIDER BRACKET
7	1	3PK8116-11	DIVIDER ANGLE BRACKET
8	1	3PK8116-14	CENTER SUPPORT WELDMENT
9	1	3RWG8116	REAR WINDOW GUARD, F-150
10	1	3RWG8116-04	CENTER BRACKET
11	1	3SP8116-01	SEAT PROTECTOR, PRO-CELL
12	2	3X04	1/4-20 x 5/8" HHMS, BLK
13	4	3X07	1/4-20 X 1-1/2 PHIL TRUSS HD MS
14	26	3X145	BLACK PLASTIC CAP
15	3	3X149	5/16-18 X 3/4 BSHCS, BK
16	6	3X16	1/4-20 WHIZ NUT
17	4	3X162	#14 x 3/4" SELF DRILLING HEX HEAD SCREW
18	20	3X16Z	1/4-20 WHIZ NUT
19	2	3X184	1/4-20x0.75, SBHCS, BLACK OXIDE
20	11	3X36	1/4-20 X 5/8 CARRIAGE BOLT
21	7	3X82	1/4-20 X 1 CARRIAGE BOLT
22	4	4G5070P1	SPACER, DIVIDER VENT PLATE
23	3	FORD OEM BOLT	VARIOUS
24	2	3RWG8116-05	HANGER PLATE

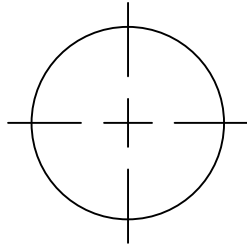

DIRECTIONS

1. CUT ALONG DASHED LINES
2. REMOVE THE B-PILLAR TRIM AND PLACE TEMPLATE INSIDE, ALIGNING CUT-OUT AREAS WITH THE CORRESPONDING FEATURE SHOWN
3. CENTER PUNCH 3 HOLE LOCATIONS THRU TEMPLATE AND DRILL/CUT 1" DIA HOLE
4. REINSTALL TRIM PANELS OVER TOP OF THE B-PILLAR BRACKETS

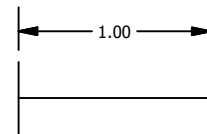
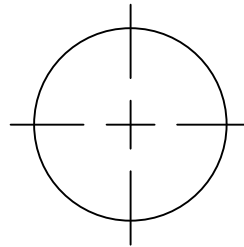

CHECK SCALE
SELECT NONE FOR PAGE SCALING
WHEN PRINTING FROM .pdf FILE

2016 F-150
B-PILLAR TRIM TEMPLATE
PASSENGER SIDE

