

INSTALLATION GUIDE

DP56C11

ABS DOOR PANEL

11 - CURRENT

DODGE CHARGER

Pro-gard[™]
PRODUCTS LLC.

STRONG | RELIABLE | SECURE

pro-gard.com
800.480.6680

THESE COMPONENTS ARE REQUIRED
TO INSTALL THE PRO-GARD ABS DOOR PANEL SYSTEM

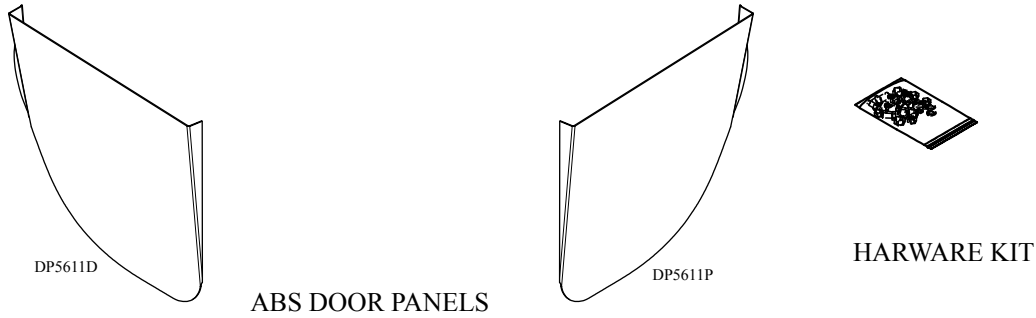

- I. Refer to the diagrams above to verify all parts were received.
- II. The following tools will be required to complete the installation.
 1. Drill with standard #2 Philips driver
 2. Drill bit 7/64" diameter
 3. 10mm Socket Wrench
- III. Read all instructions carefully before starting the assembly process.

NOTE: *Locate all Wiring, Fuel Lines, Brake Lines, and/or Cooling Lines before drilling holes or installing any Fasteners.*

- IV. OEM Door Panel Removal
 1. Find the recess/keeper in the vertical face of the manual door lock knob, use a small screwdriver to pop the keeper out. The manual lock knob can now be removed.
 2. Find the cover plates behind both door handles, use a small screwdriver to remove.
 3. Remove the 6mm bolts from behind each using a 10mm nut driver.
 4. Starting at the bottom, locate and pry the plastic fasteners loose to remove OEM door panel from the door assembly.
 5. Disconnect the door latch cable from the door handle assembly.

6. Remove the power window switch from the door panel.
7. Remove the sound/moisture barrier from the inside of the door panel for reinstallation later.
8. Secure the door latch cable to the door frame so it will not rattle.
9. Make sure the power window switch is connected to the harness, protect it from moisture and secure the harness inside the door frame away from the window travel.
10. Remove the manual door lock rod from its mount and remove.
11. Reinstall the sound/moisture barrier on the inside face of the door.

V. ABS Door Panel Installation

1. Slide the ABS door panel over the Door Panel Rail, align front to back for best alignment.
(See Fig. 1)
2. Attach with #8 x 5/8 self tapping screws.

VI. Installation is now complete

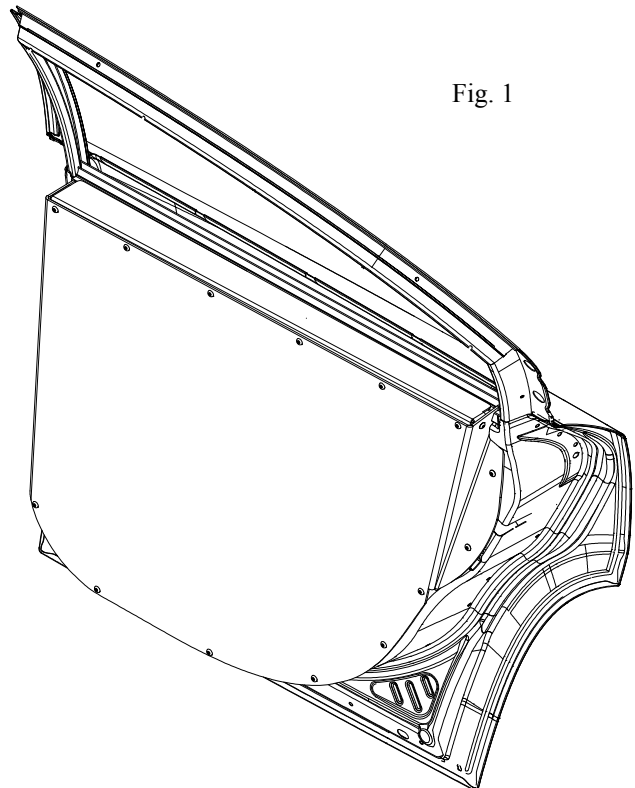

Fig. 1