

**INSTALLATION GUIDE**  
**CARGO BARRIER**  
**FORD EXPEDITION**  
**STANDARD AND EL**

**Pro-gard**<sup>™</sup>  
PRODUCTS LLC.

STRONG | RELIABLE | SECURE

**pro-gard.com**  
**800.480.6680**

THESE COMPONENTS ARE REQUIRED  
TO INSTALL THE PRO-GARD BARRIER SYSTEM

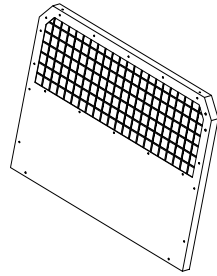

3B300X BARRIER

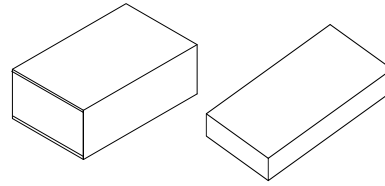

4B58EXPD09A HARDWARE/WING KIT

- I. Refer to the diagram on the last page of these instructions to verify all parts were received.
- II. The following tools will be required to complete the installation.
  - A. 1/4" drive ratchet with 7/16" socket
  - B. Phillips Screwdriver
- III. Read all instructions carefully before starting the assembly process.
- IV. Barrier Installation

A. Install the upper mounting brackets (3P652 Driver and 3P653 Passenger) to the barrier using the phillips head bolts (3X36) and whiz nuts (3X16SZ) through the holes in the top of the Barrier. Hand tighten only. See Fig. 1

B. Remove the rear OEM coat hook assemblies from the headliner. Retain the OEM fastener as it will be used to attach the upper Barrier brackets in this same location.

C. Place the Cargo Barrier Assembly on the cargo floor behind the rear seats. With the second row seats folded down begin to stand the Barrier up. While raising the Barrier swing the upper mounting brackets around toward the rear of vehicle. Align the upper mounting brackets with the coat hook mounting holes and secure loosely using the OEM fasteners. See Fig. 1

D. With the top supported, secure the Barrier at the floor using the lower mounting brackets (3P664D and 3P664P) and the OEM seat bolts at each side of the middle seat frame. See Fig. 2

FIG. 1  
DRIVER'S SIDE SHOWN

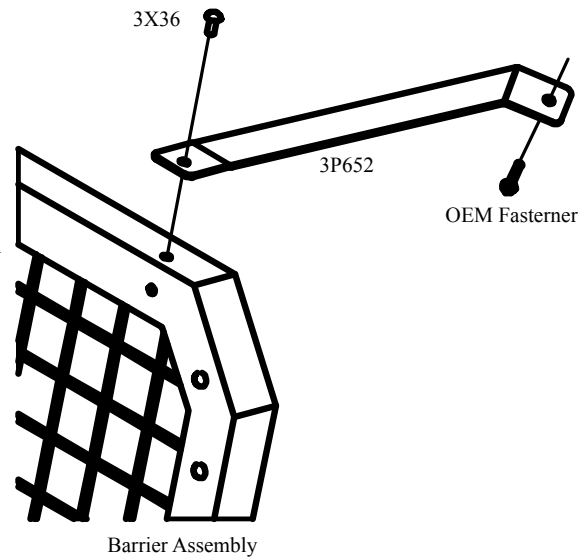

E. Attach the lower mounting brackets to the Barrier using the Phillips head bolts (3X05A) and whiz nuts (3X16) through the existing holes in the Barrier. See Fig. 2

F. Attach the Polycarbonate top panel (3P723-B) to the Barrier using the existing bolts from the top of the barrier window frame. Hand tighten fasteners only.

G. Attach the Polycarbonate Wings (3P721-B Driver and 3P722-B Passenger) between the Barrier and the interior trim using the Phillips head bolts (3X05A) and whiz nuts (3X16). Hand tighten fasteners only. See Fig. 3

H. Position the Barrier Assembly in the center of the vehicle. Adjust the Polycarbonate wings for desired fit against the interior trim and headliner. Tighten all fasteners.

I. Installation is now complete.

FIG. 2  
DRIVER'S SIDE SHOWN

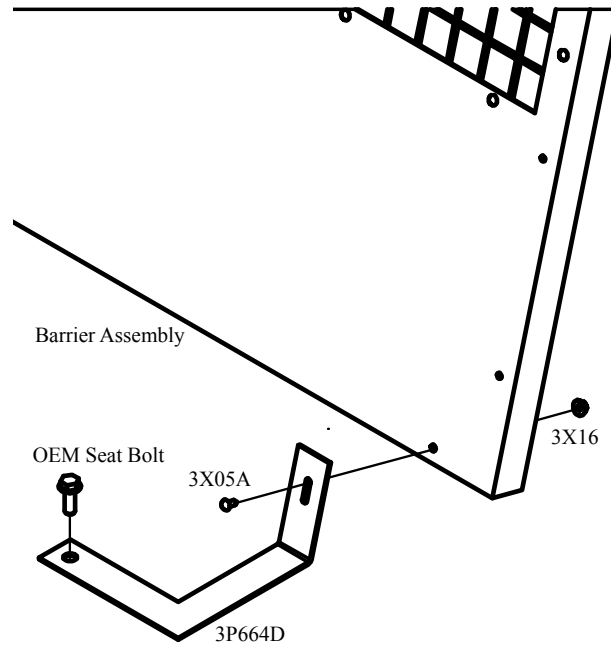

FIG. 3

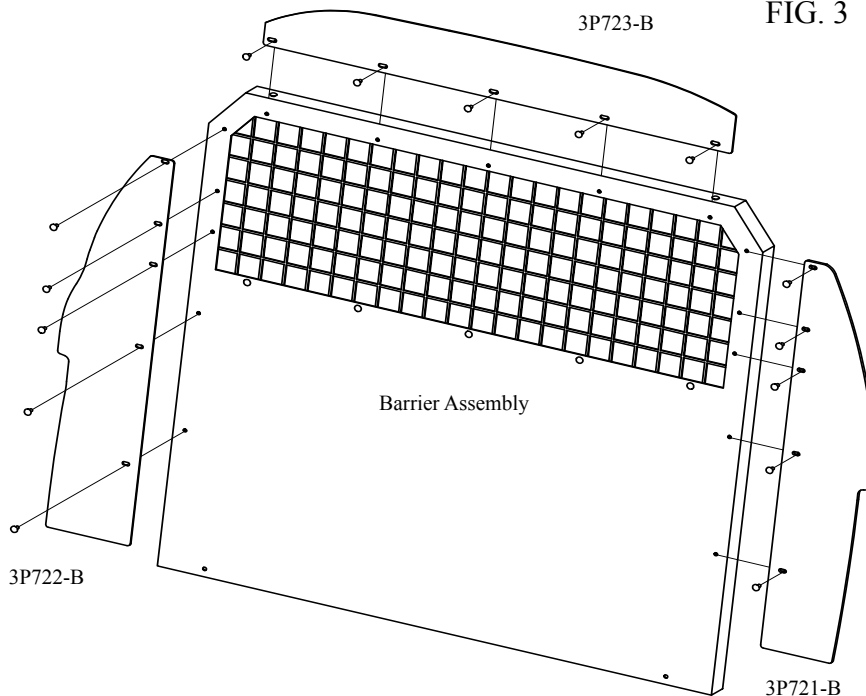
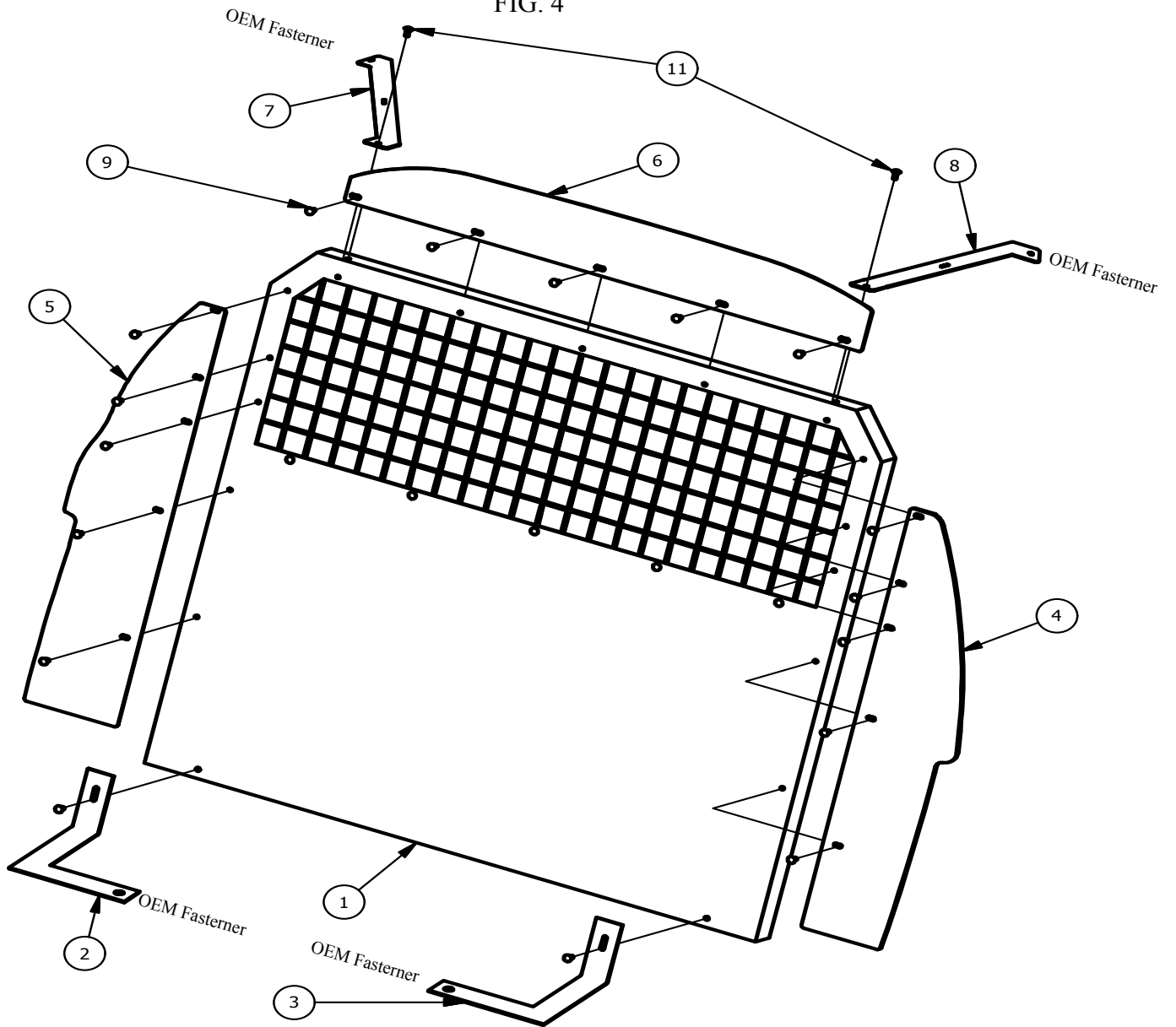

FIG. 4



4B58EXP09A			
ITEM	QTY	PART NUMBER	DESCRIPTION
2	1	3P664P-A	LOWER MOUNTING BRACKET - PASSENGER
3	1	3P664D-A	LOWER MOUNTING BRACKET - DRIVER
1	1	3P721-B	POLY WING - DRIVER
2	1	3P722-B	POLY WING - PASSENGER
3	1	3P723-B	POLY WING - CENTER
7	1	3P653-A	UPPER MOUNTING BRACKET - PASSENGER
8	1	3P652-A	UPPER MOUNTING BRACKET - DRIVER
4BHK5809			
ITEM	QTY	PART NUMBER	DESCRIPTION
5	17	3X05A	1/4-20 X 7/8 PHIL TRUSS HD MS
4	17	3X16	1/4-20 HEX WHIZ NUT - BLACK
11	2	3X36	1/4-20 X 5/8 CARRIAGE BOLT
12	2	3X16SZ	1/4-20 WHIZ WAHSER HD HEX NUT