

**INSTALLATION GUIDE**  
**CARGO BARRIER**  
**2013 - 2019**  
**FORD INTERCEPTOR UTILITY**

**Pro-gard**<sup>™</sup>  
PRODUCTS LLC.

**STRONG. RELIABLE. SECURE.**

THESE COMPONENTS ARE REQUIRED  
TO INSTALL THE PRO-GARD BARRIER SYSTEM

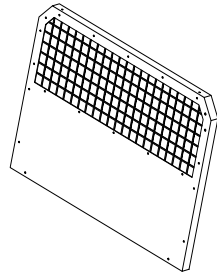

3B300 BARRIER

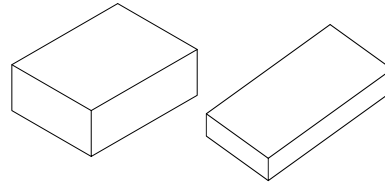

4B4713 HARDWARE/WING KIT

I. Refer to the diagram on the last page of these instructions to verify all parts were received.

II. The following tools will be required to complete the installation.

A. 3/8" drive ratchet with 13mm socket and 15mm socket (deep)

B. 7/16" wrench or 3/8" drive ratchet with 7/16" socket

III. Read all instructions carefully before starting the assembly process.

IV. Rear Mounting Bracket Installation

A. Remove the Driver OEM Rear Pocket Trim Panel, located on the Rear Quarter Trim, just below the Upper Contents Tray. Loosen the two 15mm bolt heads that secure the Cross Member Bracket. (See FIG. 1)

B. Place the Driver's Rear Mounting Bracket (3B4713-02D) under the two bolts and slide the rear mounting bracket in as far as it will go.

C. Repeat for Passenger Side using Passenger's Rear Mounting Bracket (3B4713-02P)

V. Front Mounting Bracket Installation

A. Locate the two bolts that secure the load floor to the vehicle. Remove the OEM Bolt and leave the OEM Spacer in the Load Floor. Install 4G5070P11 black Spacer that is supplied with the hardware kit. Place the Front Mounting Bracket (3B4713-01D) on top of the load floor, and use the supplied bolt (3X155) and lock washer (3X194) to secure the bracket. (See FIG. 2)

B. Repeat for Passenger Side using Passenger's Front Mounting Bracket (3B4713-01P)

C. The load floor has a small portion that extends past the mounting brackets. This will need to be removed **if installing Out Board Seat Belts** by using a utility knife to cut along the flap that allows the floor to flex.

FIG 1.  
DRIVER'S SIDE SHOWN

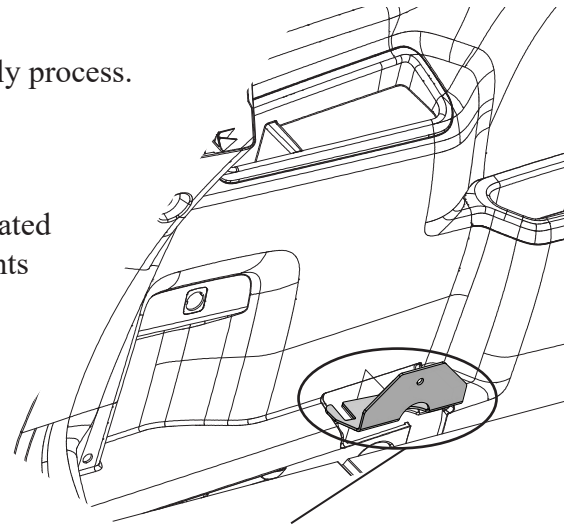

3B4713-02D

## VI. Barrier Installation

A. Place the cargo barrier with the flat surface against the back of the front mounting brackets (3B4713-01D&P). Install two carriage bolts (3X36) in each of the front mounting brackets. Slide the barrier into place against the front mounting bracket and install 2 whiz nuts (3X16Z) to secure the barrier to the front mounting brackets (3B4713-01D). (See Fig. 3)

B. Repeat for Passenger's side

**NOTE:** *The front of the barrier should sit just behind the Front hinge point of the load floor, allowing access to the factory equipment and fuses with the barrier installed.*

FIG. 2  
DRIVER'S SIDE SHOWN

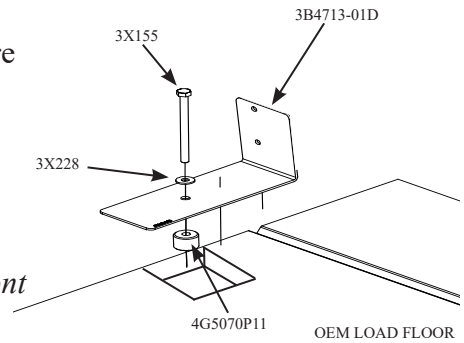

## VII. Installing the Mounting Straps

A. The mounting strap (3B4713-05D&P) is the last bracket to install. The end with the slot will connect to the rear mounting bracket (3B471302D) using a carriage bolt (3X82) and a whiz nut (3X16Z). The end with a hole will connect to the barrier as shown with a carriage bolt (3X36) and a whiz nut (3X16Z). (See Fig. 4)

B. Repeat for Passenger's side

FIG. 3  
DRIVER'S SIDE SHOWN

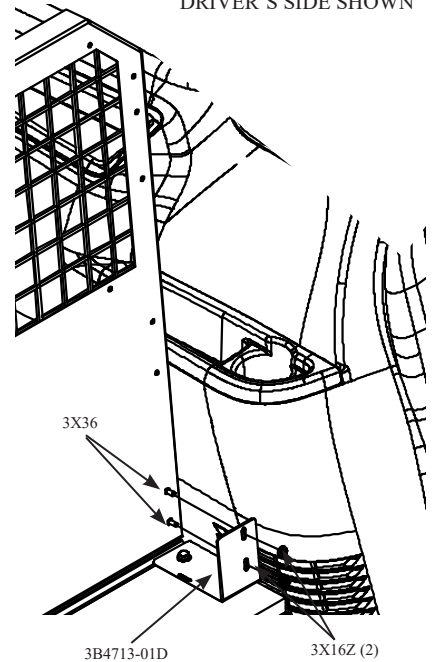
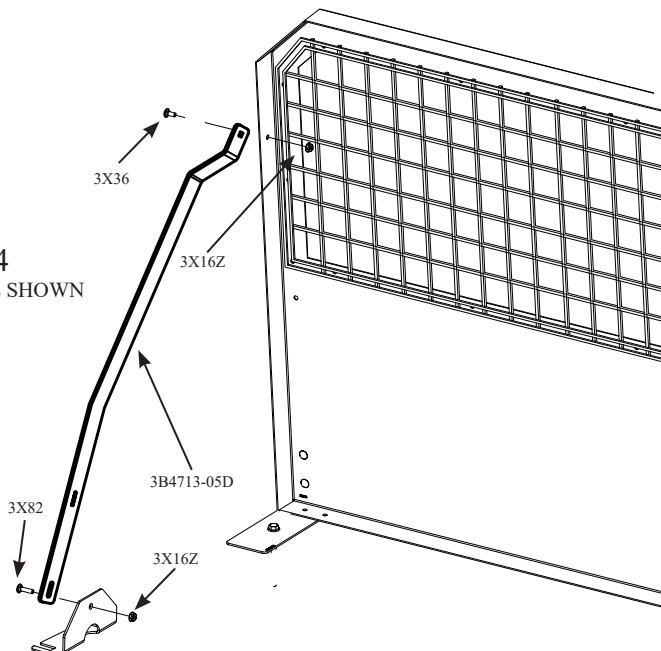

FIG. 4  
DRIVER'S SIDE SHOWN



## VIII. Installing Filler Wings

A. Install the Wing Mounting Brackets (3P929) to the “front” side of the filler wings, with the bend facing forward. (See Fig. 5)

B. **OEM Seats:** Place the Filler Wing Assemblies against the front side of the Barrier. Fasten the assemblies using the supplied bolts (3X03) and nuts (3X16). Ensure that the Filler Wings can flex forward in the event of a crash. (See Fig. 5)

C. **Transport Seat:** When installing the transport seat ensure filler wings are installed on top of the seat, in front of the seat support bracket to allow proper flex for airbag compliance and preventing prisoner access points to the cargo area.

**NOTE:** *Installation of the Filler Wings according to these instructions is critical in their ability to function properly in the event of Side Air Bag deployment.*

IX. Audit overall installation, insure that all fasteners are tight.

X. Installation is now complete.

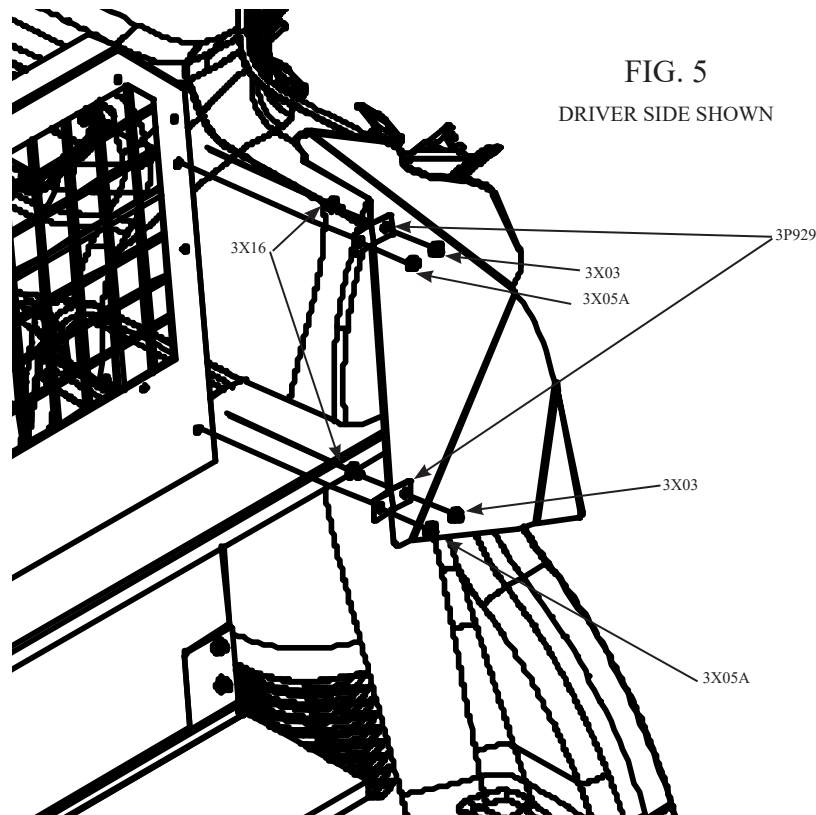

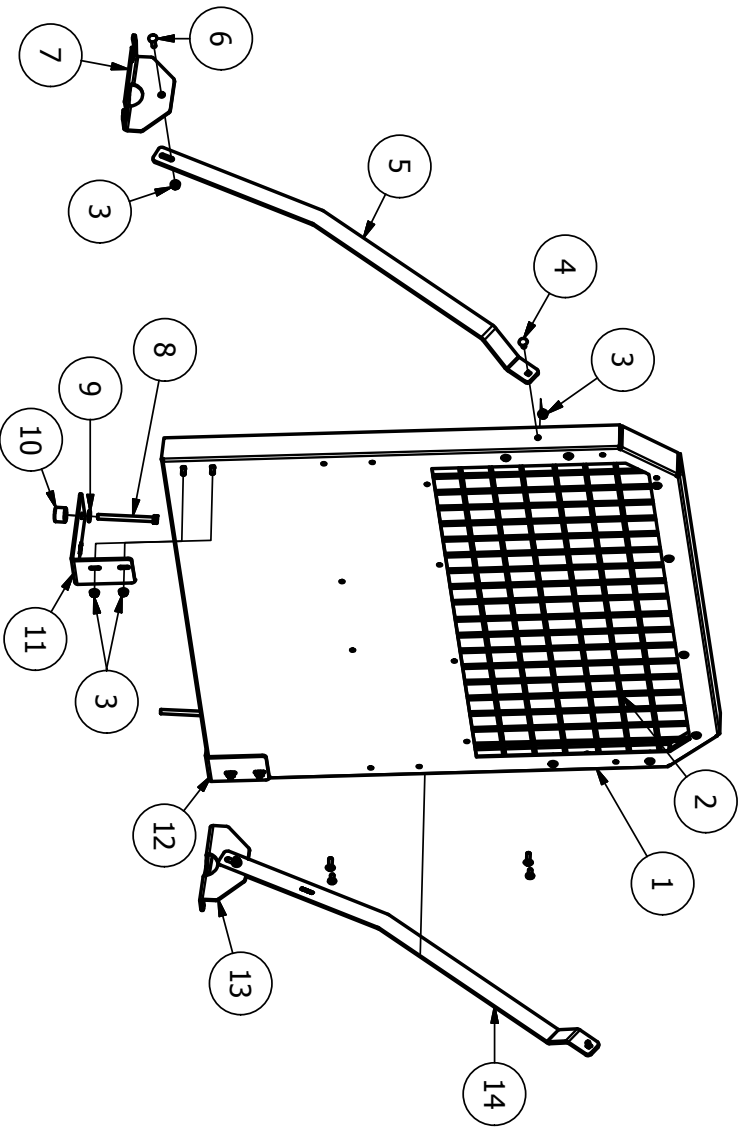

CARGO BARRIER HARDWARE KIT - PARTS LIST			
ITEM	QTY	PART NUMBER	DESCRIPTION
1	1	VARIABLES BY ORDER	UTILITY INTERCEPTOR CARGO BARRIER
2	1	VARIABLES BY ORDER	CARGO BARRIER WINDOW (WIRE OR CLEAR POLYCARB)
3	8	3X16Z	1/4-20 WHIZ NUT
4	6	3X36	1/4-20 X 5/8 CARRIAGE BOLT
5	1	3B4713-05P	BARRIER SUPPORT STRAP, PASSENGER
6	2	3X82	1/4-20 X 1 CARRIAGE BOLT
7	1	3B4713-02P	BARRIER MOUNT BRACKET, REAR, PASSENGER
8	2	3X155	M8-1.25x100mm HEX CAP SCREW ZINC
9	2	3X228	3/8" SPLIT LOCK WASHER, BLACK
10	2	4G5070P11	5/8" BLACK PLASTIC SPACER
11	1	3B4713-01P	BARRIER MOUNT BRACKET, FRONT, PASSENGER
12	1	3B4713-01D	BARRIER MOUNT BRACKET, FRONT, DRIVER
13	1	3B4713-02D	BARRIER MOUNT BRACKET, REAR, DRIVER
14	1	3B4713-05D	BARRIER SUPPORT STRAP, DRIVER

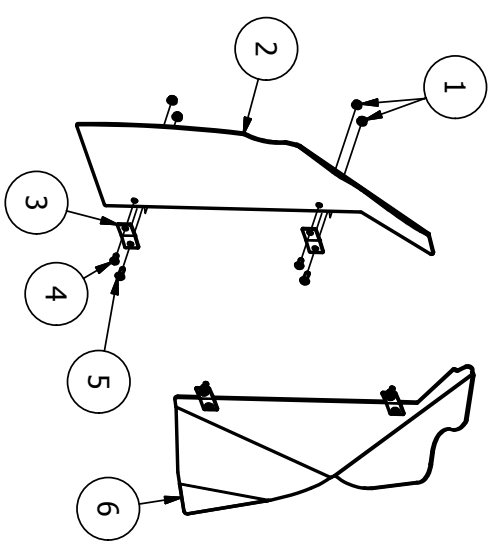

CARGO BARRIER WING KIT - PARTS LIST			
ITEM	QTY	PART NUMBER	DESCRIPTION
1	8	3X16	1/4-20 WHIZ NUT, BLACK
2	1	W4713-BP	PASSENGER SIDE AIR BAG WING
3	4	3B929	BARRIER WING MOUNT BRACKET
4	4	3X03	1/4-20 X 5/8" PHILLIPS SCREW, BLACK
5	4	3X05A	1/4-20 X 7/8" PHILLIPS SCREW, BLACK
6	1	W4713-BD	DRIVER SIDE AIR BAG WING