

## **INSTALLATION GUIDE**

**P1500 PRO-CELL**

**2011 - CURRENT**

**CHEVY CAPRICE**

**Pro-gard**<sup>™</sup>  
PRODUCTS LLC.

**STRONG | RELIABLE | SECURE**

**pro-gard.com**  
**800.480.6680**

THESE COMPONENTS ARE REQUIRED  
TO INSTALL THE PRO-GARD PRO-CELL PARTITION SYSTEM

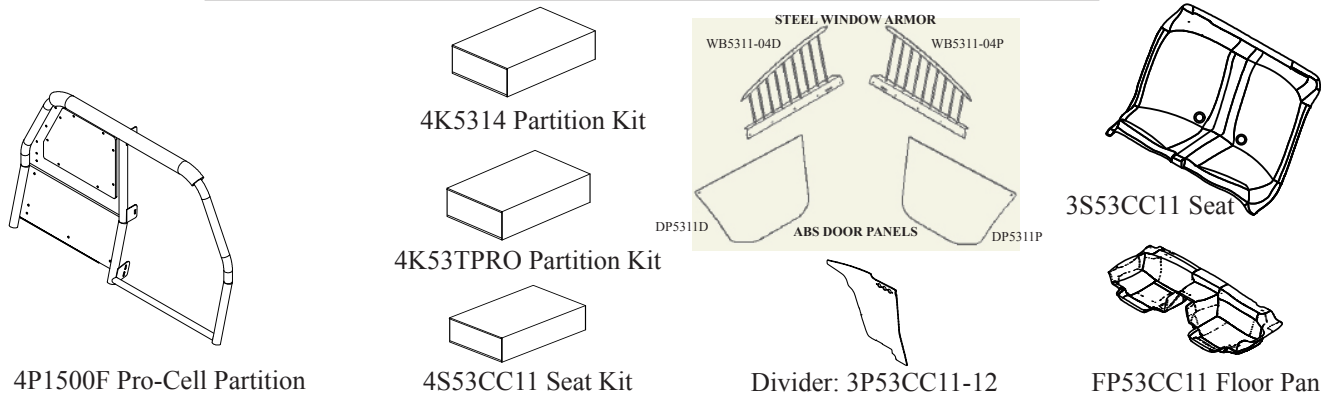

I. Refer to the diagram on the last page of these instructions to verify all parts were received.

II. The following tools will be required to complete the installation.

- A. 1/4" drive ratchet with 7/16" socket
- B. 3/16" Allen key
- C. 1" Hole saw
- D. Drill with 3/8" Socket
- E. T15 Torx Driver

III. Read all instructions carefully before starting the assembly process.

**NOTE: Locate all Wiring, Fuel Lines, Brake Lines, and/or Cooling Lines before drilling holes or installing Fasteners.**

IV. B-Pillar Bracket Installation

A. Remove Center B-pillar trim on the Passenger-side.  
This will be reinstated after bracket installation. (See Fig. 1)

B. Place the Passenger B-pillar bracket (3P5314-03)  
against the B-pillar face. (See Fig. 2).

C. Orient the B-pillar bracket so the bottom tab fits into the slot on the B-pillar and the formed edges wrap around the B-pillar. Push up on the Bracket until the tab is at the top of the slot. Using the supplied Self-Drilling screws (3X162) secure the B-pillar bracket to the vehicle b-pillar. (See Fig. 2)

**NOTE: It is critical that the seat belt strap be on the outside of the B-pillar bracket (See Fig. 3)**

D. Repeat steps A thru C for Driver's side of vehicle.

FIG. 1  
PASSENGER SIDE SHOWN

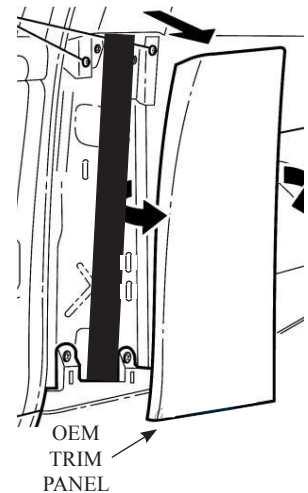
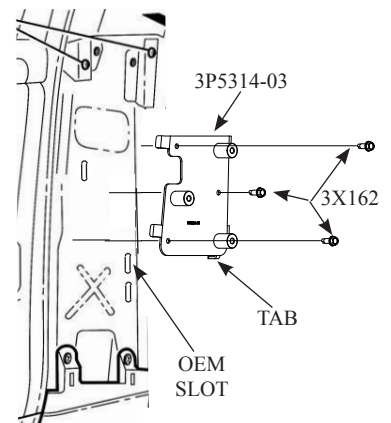
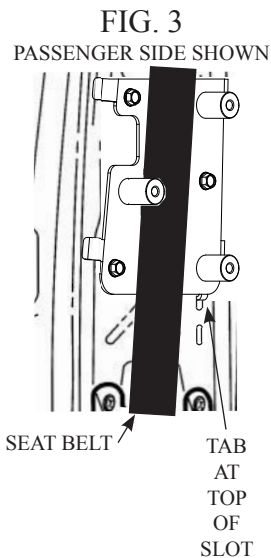

FIG. 2  
PASSENGER SIDE SHOWN





## V. Drilling B-pillar Trim Panels

- A. Carefully align the template per its included instructions. Using a 1" Hole Saw drill the clearance holes as marked on the template. Replacement of sound insulation is optional.
- B. Replace the trim panel, insuring that the standoff's protrude through the panel. (See Fig. 4)

**FIG. 4**  
DRIVER'S SIDE SHOWN

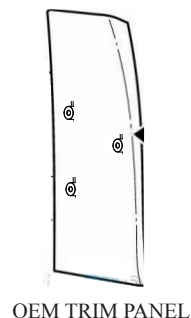

## VI. Installation of Transport Seat and Floor Pan

### A. Removing the OEM Seat

1. Begin by lifting the front of the lower seat cushion out from the plastic snaps in the floor. Once the seat is free, remove it from the vehicle (See Fig. 6).
2. Remove the seat belts by removing the two 17mm OEM nuts from their mounting studs. Do not remove the shoulder straps anchored at each side of the vehicle.
3. Remove the OEM seat back cushion by removing four 17mm nuts from the lower mounting brackets near the seat belt mounting studs.
4. Also remove the remaining two 13mm nuts holding lower child restraint brackets (3 pcs) and remove the brackets from the vehicle. (Fig. 5)

*Note: This is necessary for the Pro-gard Seat to fit properly in position.*

**Fig. 5**

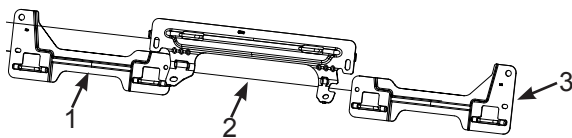

**Fig. 6**  
DRIVER SIDE SHOWN

REAR SEAT LOWER CUSHION

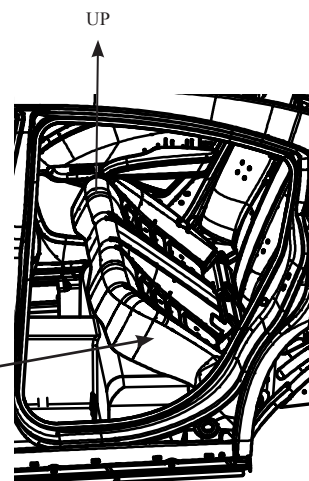

## B. Removing the OEM Trim Panels

Fig. 7 Driver Side Scuff Panel

1. Remove the T15 Torx screw from the rear tab of the Rear Door Scuff Plates and then remove the Rear Door Scuff Plates on the Driver and Passenger-side. These will be reinstalled after the ABS Floor Pan Installation. (See Fig. 7)
2. Remove the upper seat transition trim that extends from the scuff plates to the small window near the outer shoulder harnesses on both the Driver and Passenger sides of the vehicle. (See Fig. 8)
3. Remove Center B-Pillar trim Panel. Then remove the B-Pillar lower transition trim panel on the passenger side of the vehicle.

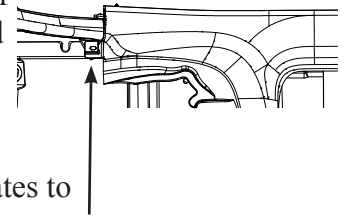

Remove T15 Torx Screw

## C. Installing the ABS Floor Pan

1. Place the ABS Floor Pan in the vehicle, making sure that there are no objects underneath of it. Insure that the Floor Pan is all the way back and down against the rear seat area.

*Note: The floor pan does not cover the OEM seat grommets.*

2. Reinstall the B-Pillar lower transition panels (Fig. 9) and the OEM Rear Door Scuff Plates on the Driver and Passenger-side.

*Note: The Side Scuff Plates and the B-Pillar Transition Trim go on top of the ABS Floor Pan.*

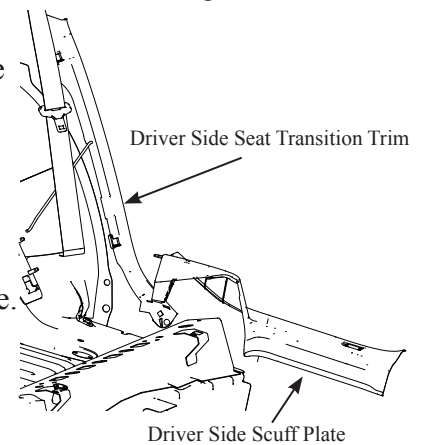

Fig. 8

## D. Installing the ABS Transport Seat

1. Preparing Transport Seat for installation:

- a. If installing a Pro-Gard Pro-Cell Kit with center divider then, go to Step b. If not installing a center divider, skip to Step 2.

- b. Attach the (3P214) Divider Mounting Brackets using the supplied bolts (3X36) and whiz nuts (3X16Z), before installing the seat in to the vehicle. (See Fig. 10)

Remove T15 Torx Screw

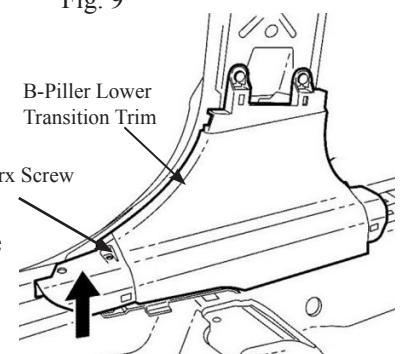
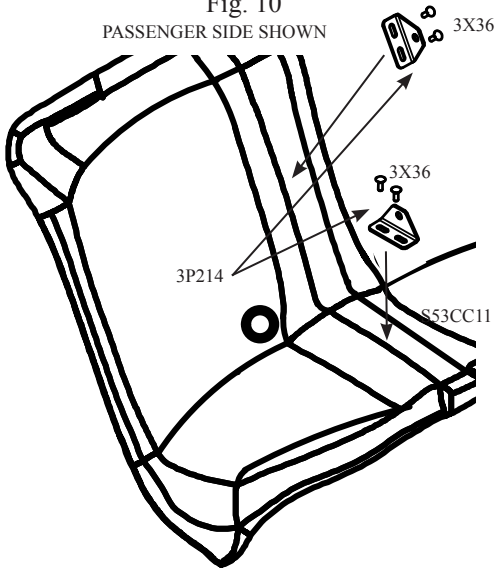

Fig. 9

*Note: The flat side of the bracket should face the driver's side; the divider will mount above the angled portion and flat against the bracket from the passenger side.*

2. Place the seat in the vehicle. Make sure the seat is tucked behind the outer shoulder straps and is flush against the frame of the seat back. The seat will overlap the back edge of the floor pan. The upper trimmed edge of the seat should be flush with the top of the rear deck.

Fig. 10  
PASSENGER SIDE SHOWN



3. Be sure the seat belts are on the outside of the seat and operate freely.

*Note: The gas tank is under the rear seat in this vehicle. Use pre-drilled locations and supplied hardware only!*

**Caution:** Locate all Wiring, Fuel Lines, Brake Lines, and/or Cooling, Lines before drilling holes or installing fasteners.

4. Starting at the top of the transport seat along the edge near the rear deck. Fasten with four 1-1/2" long (3X77) self-tapping screws and (3X78) finish washers through the surface on the seat where the raised Pro-Gard lettering is seen. Be sure the upper trimmed edge of the seat is flush with the top edge of the rear deck.
5. Using four more 1-1/2" long (3X77) self-tapping screws and (3X78) finish washers, secure the front lower portion of the seat to the seat frame of the vehicle through the four recessed screw mounting locations.

#### E. Installing the OEM Seatbelts and ABS Cover Plates.

1. Insert the passenger side belt buckle through the passenger side seat cover plate (The plate with the smaller hole). Insert into the side with the rough surface and pass the bracket through the plate also. Slide the plate up the seat belt to allow access to bolt the buckle to the stud under the seat.

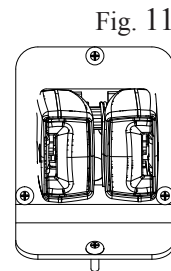

Fig. 11

2. Insert the seat belts and buckles through the holes in the seat and reattach to OEM mounting studs with OEM nuts.
3. Slide cover plate assemblies over the buckles into the recesses in the seat. Orient and secure each cover plate using the four (3X72) Phillips truss head screws. (Fig. 11)

#### VII. Installing Partition Mounting Plate

- A. Attach the Passenger-side Mounting Plate (3PRT5311-02P) and Driver-side Mounting Plate (3PRT5311-04D) using the supplied 5/16-18 x 3/4" Button head screws (3X149) to the Standoff's protruding through the B-pillar trim (See Fig. 12). Hand tighten only for now.

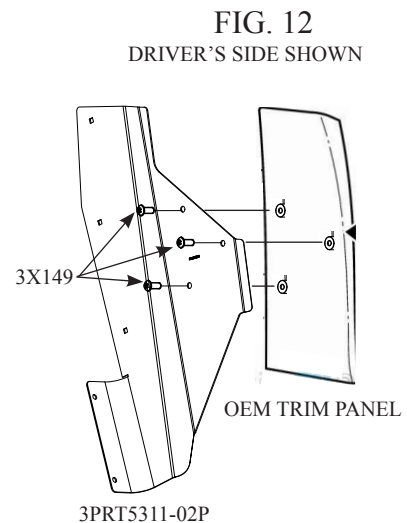

FIG. 12  
DRIVER'S SIDE SHOWN

IX. Pro-Cell Partition Installation

- A. Due to the weight and size of the partition, assistance from another party is highly recommended. Insert the partition into the vehicle, lift and position the partition so that it aligns with the Partition Mounting Plates, using the supplied 1/4-20 x 5/8" Carriage Bolts (3X36) and 1/4-20 Whiz nuts (3X16Z) secure the Partition to the Mounting Plates (See Fig. 14). Hand tighten only.
- B. Rotate the partition forward towards the front of the vehicle. The top of the partition should fit snug against the roof of the vehicle.
- C. Tighten all partition mounting hardware.
- D. Install the partition mounted seat protector (3SP5314-05) on the back side of the partition. Slide the seat protector down to fit flat against the floor pan and tighten the corresponding carriage bolts. (See Fig. 14)
- E. Audit the overall installation for fit and function of all components.

FIG. 13  
PASSENGER SIDE SHOWN

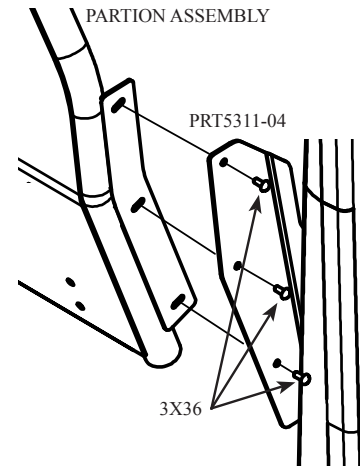
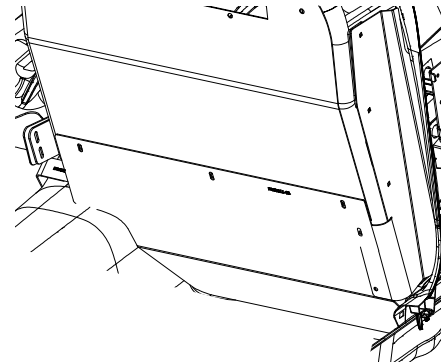

FIG. 14



## X. Pro-Cell Divider Installation

- A. Assemble vent plate over 3 large diameter air holes. Use (black ABS) spacers between plate and center divider. Secure using the long, Philips head screws, black whiz nuts, and black caps. (See fig. 15)
- B. Insert the center divider from the passenger side of the vehicle. Be sure to start with the tail of the divider, aimed toward the rear window and speaker deck area. Once you have inserted the divider, press the divider against the seat mount brackets, and then to the partition tabs Mark all mounting hole locations on the divider with a felt tip marker then remove the divider for drilling or drill in place if desired.
- C. Once you've installed the divider, mount the divider deck bracket (3P214) in place. Remove the center child restraint harness loop and take the bolt and stand-off off the loop. Insert the bolt through the bracket (3P214) and slide the stand-off over the bolt. Reinstall the stand-off, bracket, and bolt into the hole where the loop was removed from. Position the divider tail over the bracket. (See Fig. 16). (Bracket 3P214 is black with two holes)
- D. Use the existing holes and slots on the bracket as a template, and drill 9/32" holes to secure each area using the 3X61 carriage bolts and the 3X16Z whiz nuts.

FIG. 15

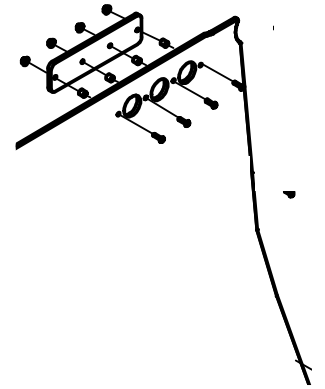
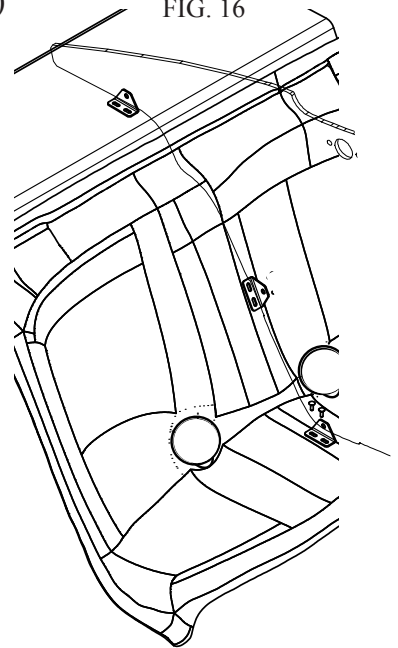

FIG. 16



## XI. Air Bag wing Installation

- A. The Filler Wings and their mounting hardware are packed in separate box marked Wing Kit. Install the Filler Wings according to their included Install Instructions. (See Fig. 17)

## XII. Door Panel Instalation.

- A. The Door Panels and their mounting hardware are packed in separate box marked DP5611 . Install the Door Panels according to their included Install Instructions. (See Fig. 18)

FIG. 17

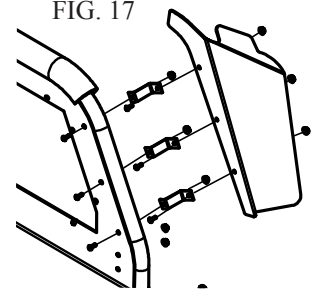

## XIII. Window Barrier Instalation

- A. The Window Barriers and their mounting hardware are packed in separate box marked WB56C11. Install the Window Barriers according to their included Install Instructions. (See Fig. 18)

## XIV. Finalize Instalation

- A. Audit the overall installation for fit and function of all components. Once satisfied, insure all fasteners are tight.
- B. Instalation is now complete

FIG. 18

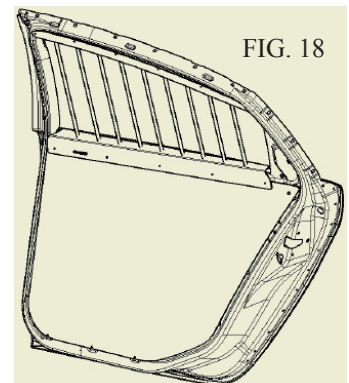

PARTS LIST			DESCRIPTION
ITEM	QTY	PART NUMBER	
1	1	4P1500F	P1500 PRO-CELL PARTITION ASSEMBLY
2	1	3P5314-03	B-PILLAR BRACKET WELDMENT, PASSENGER
3	1	PRT5311-04	B-PILLAR SHEET METAL, PASSENGER
4	1	13P5314-02	B-PILLAR BRACKET WELDMENT, DRIVER
5	1	PRT5311-03	B-PILLAR SHEET METAL, DRIVER
6	1	3SP5314-05	STEEL SEAT PROTECTOR
7	1	3P53CC11-12	3/8" POLYCARBONATE DIVIDER
8	1	3P8010	DIVIDER VENT PLATE
9	1	3FP53CC1	ABS FLOOR PAN
10	1	3S53CC11	ABS TRANSPORT SEAT
11	1	3S53CC11-01	SEAT BELT BUCKLE PUCK - PASSENGER
12	1	3S53CC11-02	SEAT BELT BUCKLE PUCK - DRIVER
13	1	3S601	FLOOR PAN DRAIN PLUG (INSTALLATION OPTIONAL - MUST DRILL 1-1/2" HOLE)
14	1	W5311-AB	PASSENGER & DRIVER SIDE AIRBAG WING
15	2	WB53CC11 (WB53CC11P) (WB53NPCC11) (WB53NPCC11P)	STEEL WINDOW BARRIER (POLYCARBONATE WINDOW BARRIER) (STEEL WINDOW BARRIER WITH OEM DP) (POLY. WINDOW BARRIER WITH OEM DP)
16	2	DP5311	ABS DOOR PANELS (P&D) *OPTIONAL*
17	2	3P214	LOWER DIVIDER BRACKETS (BOLT TO TRANSPORT SEAT)
18	1	3P214	UPPER DIVIDER BRACKET (BOLTS TO REAR DECK PANEL)
19	6	3P928	AIRBAG WING Z-BRACKET (BOLT TO FRONT OF PARTITION)
20	30	3X16Z	1/4-20 WHIZ NUT
21	9	3X145	BLACK PLASTIC CAP FOR 1/4-20 NUTS
22	6	3X162	1/4x3/4 SELF DRILLING SCREW
23	6	3X149	5/16-18 X 3/4 BSHCS, BK
24	12	3X92	1/4-20 X 1/2 CARRIAGE BOLT
25	6	3X36	1/4-20 X 5/8 CARRIAGE BOLT
26	9	3X61	1/4-20 X 3/4 CARRIAGE BOLT
27	3	3X82	1/4-20 X 1 CARRIAGE BOLT
28	8	3X72	8-32 X 5/8 PHIL PAN HD NS (FOR SEAT PUCKS)
29	8	3X77	#10 - 1 1/2" OVAL, PHILIPS HEAD SELF TAPPING SCREW (SECURES SEAT TO VEHICLE)
30	8	3X78	#10 FINISH WASHER (SECURES SEAT TO VEHICLE)

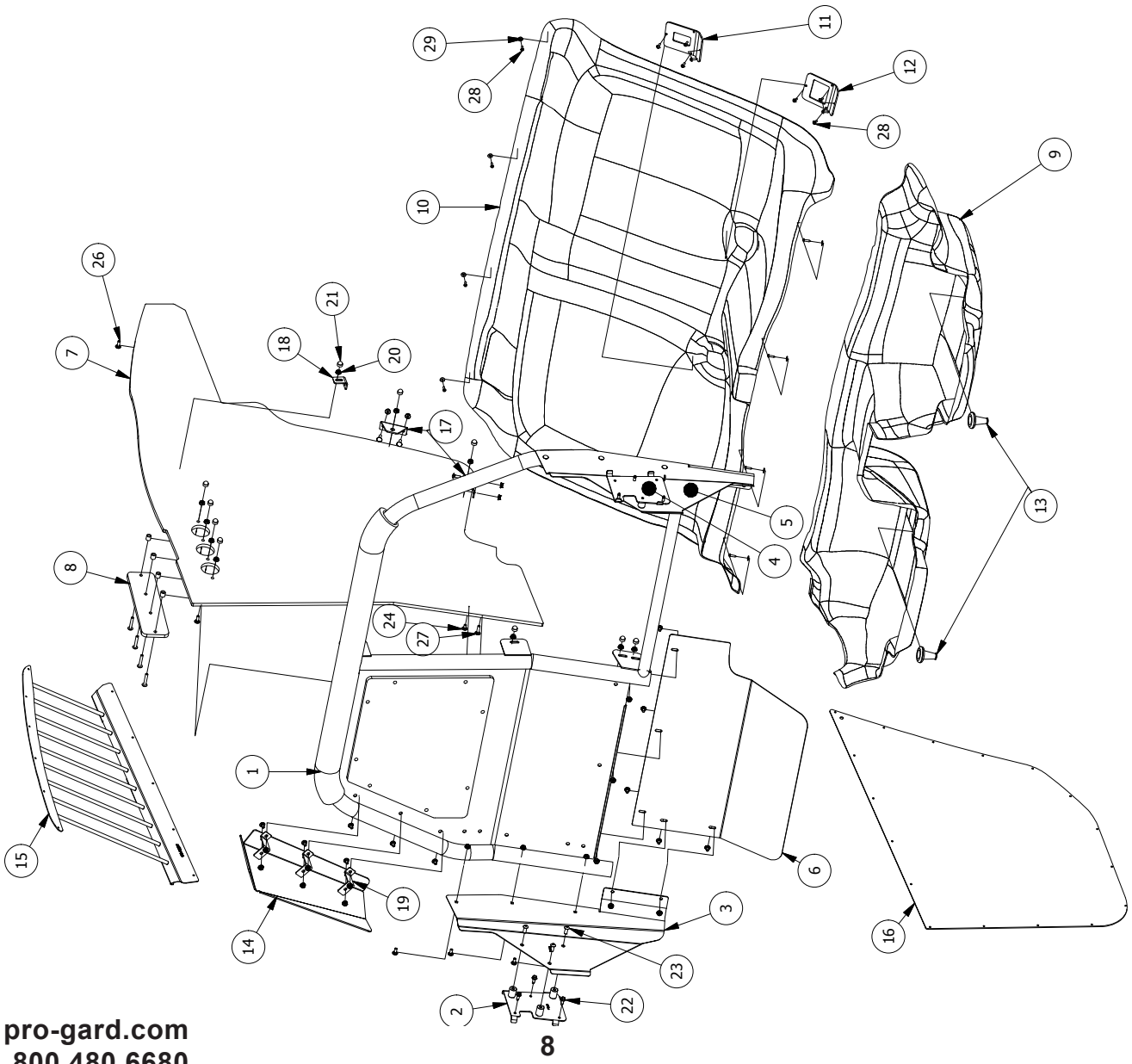





# DRIVER

CUT OUT CROSS HATCHED AREAS  
AND ALONG DASHED LINES

CENTER PUNCH 3 HOLE LOCATIONS  
THRU TEMPLATE & DRILL/CUT 1" DIA. HOLE

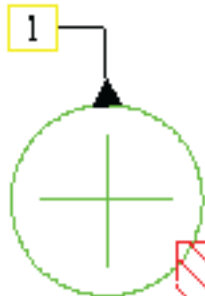

1

LINE UP CUT OUTS WITH  
TABS ON TRIM PANEL

View from rear of  
B-Pillar Trim

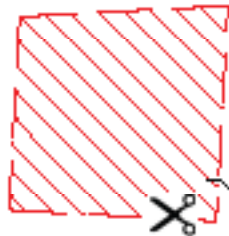

2



TRIM 1/8" OFF  
TOP OF THIS TAB



CHECK SCALE

SELECT "NONE" FOR PAGE  
SCALING WHEN PRINTING  
FROM .pdf FILE

3

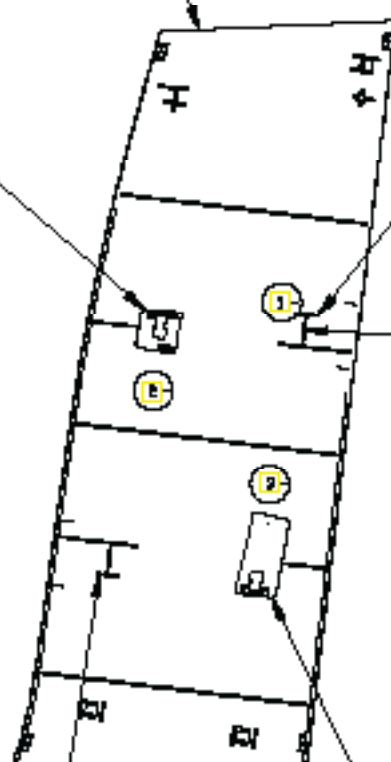
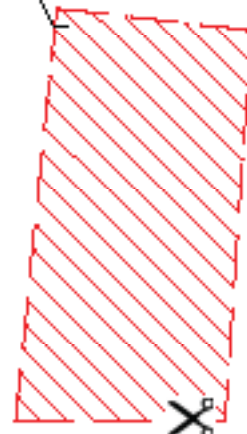
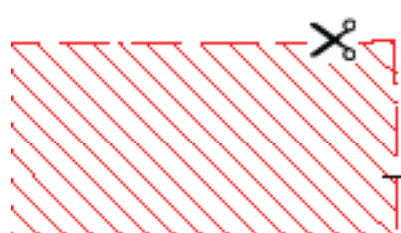



CUT OUT CROSS HATCHED AREAS  
AND ALONG DASHED LINES

# PASSENGER

